

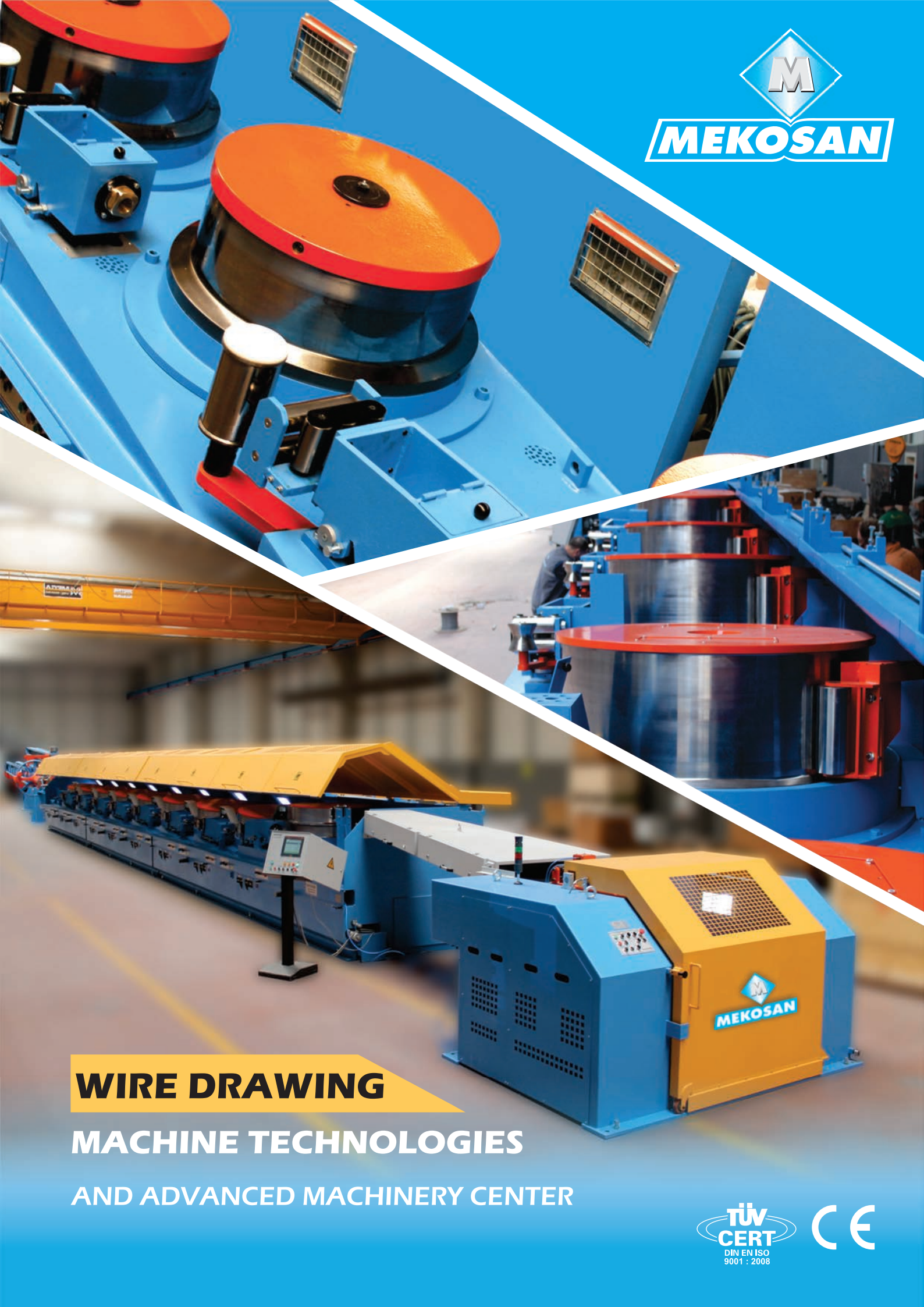

MEKOSAN



WIRE DRAWING

MACHINE TECHNOLOGIES

AND ADVANCED MACHINERY CENTER





MEKOSAN

COMPANY PROFILE :

Mekosan was established in 1997 in the industrial city of Kayseri, Turkey. A group of experienced engineers with a long history in the steel wire & cable industry started the design and manufacture of automated process equipment for wire drawing systems. At the beginning wire drawing machine and the automation systems are the basic production and business for Mekosan. In the time being Mekosan has experiences in different branches. Mekosan operates out of three production plants in Kayseri with more than 35,000 m² area. There are more than 150 employees including 40 engineers. Mekosan is also a distributor and drive alliance partners of ABB drives and motors in Turkey. Mekosan wants to be a well-known company in the world with its technology and quality. With this vision %60 of our production is exported to countries all over the world.

The main businesses can be classified as:

- Wire Drawing Lines & Accessories for Steel , Copper and Aluminum Wire.
- Nail Packaging Machines.
- Wire Annealing Furnaces.
- Hot Dip Galvanizing Lines.
- Automatic Packaging Machines for Tubes and Profiles.
- Automatic Painting Machines for Tubes and Profiles.
- Automation System Engineering.





INDEX

3-10	Wire Drawing Machine MKS 300 - 710
11-20	Wire Drawing Machine MKS 800 - 1200
21-28	Bull Block Wire Drawing Machine MKS - BL710
29-32	HandStand Type Mono Block Wire Drawing Machine MKS - MN
33-38	Wet Wire Drawing Machine
39-52	Pay-offs
53-60	Coilers
61-66	Spoolers
67-72	Wire Pre-Treatment Machine
73-78	Bell Type Electrical Annealing Furnace MKS-BELL
79-86	Accessories
87-91	Options
92-93	Automation Systems Engineering

WIRE DRAWING MACHINE



USER FRIENDLY OPERATOR PANEL



ACCUMULATOR BLOCK

- High and Low Carbon Steel Wire
- High Speed
- Block and Die Cooling System
- Speed Control by Dancer Arms
- Options:
 - ▶ Soap Stirrer
 - ▶ Rotating Die Holder
 - ▶ Dust Extraction, etc.

WIRE DRAWING MACHINE

- Welded Construction Housing
- Pneumatic Brake
- Block Skip
- Wire Break Detection





- The drawing blocks are made of steel cast iron Capstan coated with tungsten carbide.
- Water flow displays for dies and blocks.
- Easy to use control buttons for each block.

WIRE DRAWING MACHINE

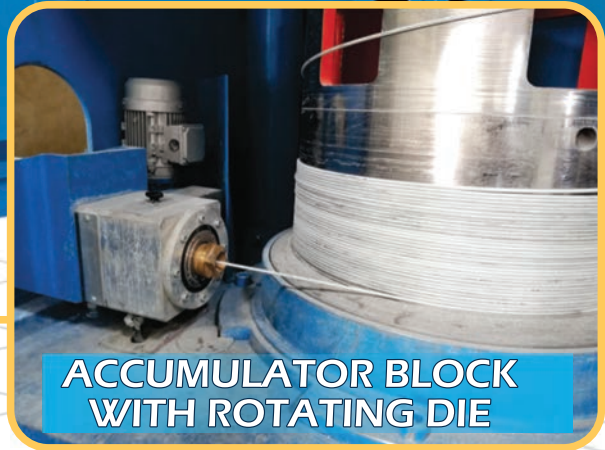

**ACCUMULATOR BLOCK
WITH ROTATING DIE**

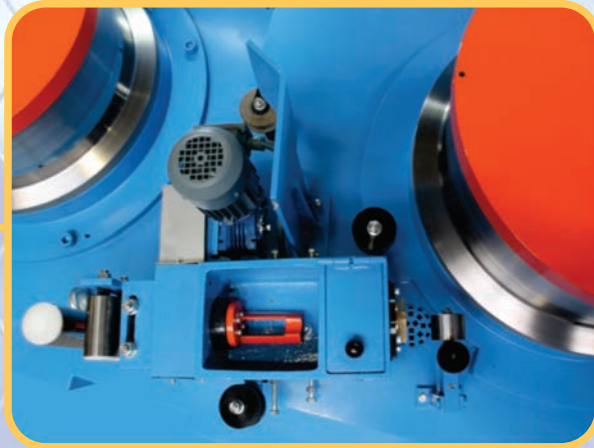

LUBRICANT MIXER

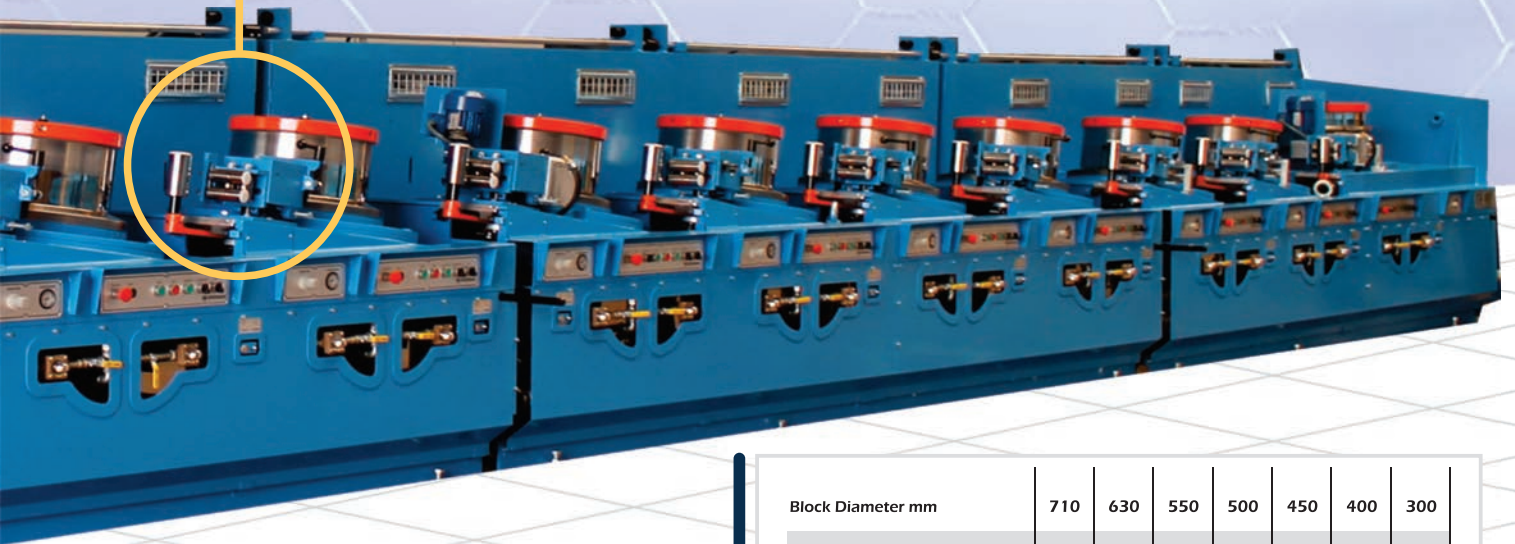

Block Diameter mm	710	630	550	500	450	400	300
Max Motor Power kW	75	55	45	37	30	22	15
Max Inlet Wire Q (c=0.80%) mm	7.00	6.50	5.50	5.50	3.50	2.80	2.20
Max Inlet Wire Q (c=0.20%) mm	8.00	7.00	6.50	6.00	4.00	3.50	3.00
Min Outlet Wire Q mm	2.00	1.70	1.30	1.30	0.80	0.60	0.50
Max Speed m/sec	20	25	25	25	25	25	25

WIRE DRAWING MACHINE

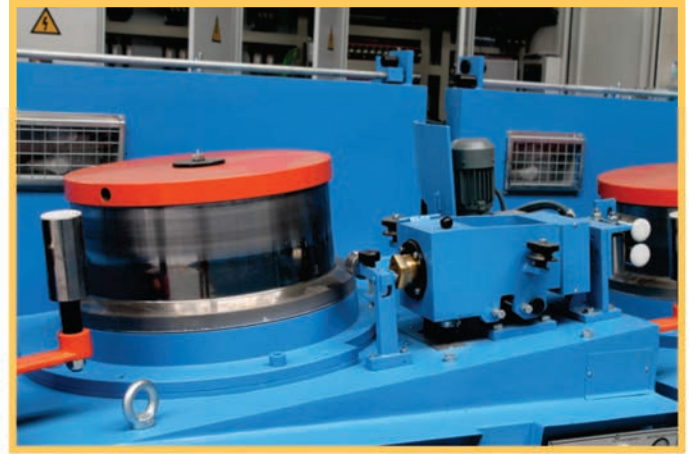

- ⚙ Die box is adjustable up-down & left-right and has got a direct cooling of the die.
- ⚙ Pressure die can be used.



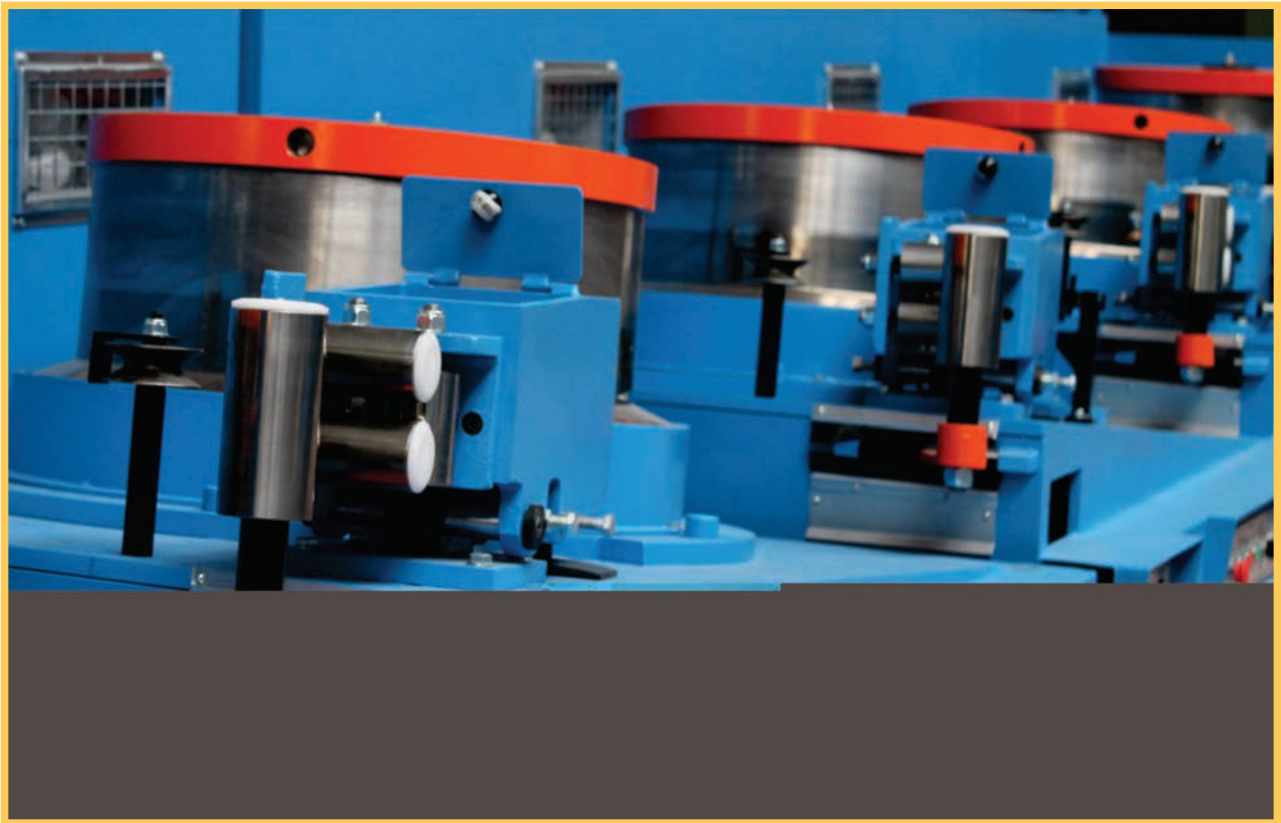
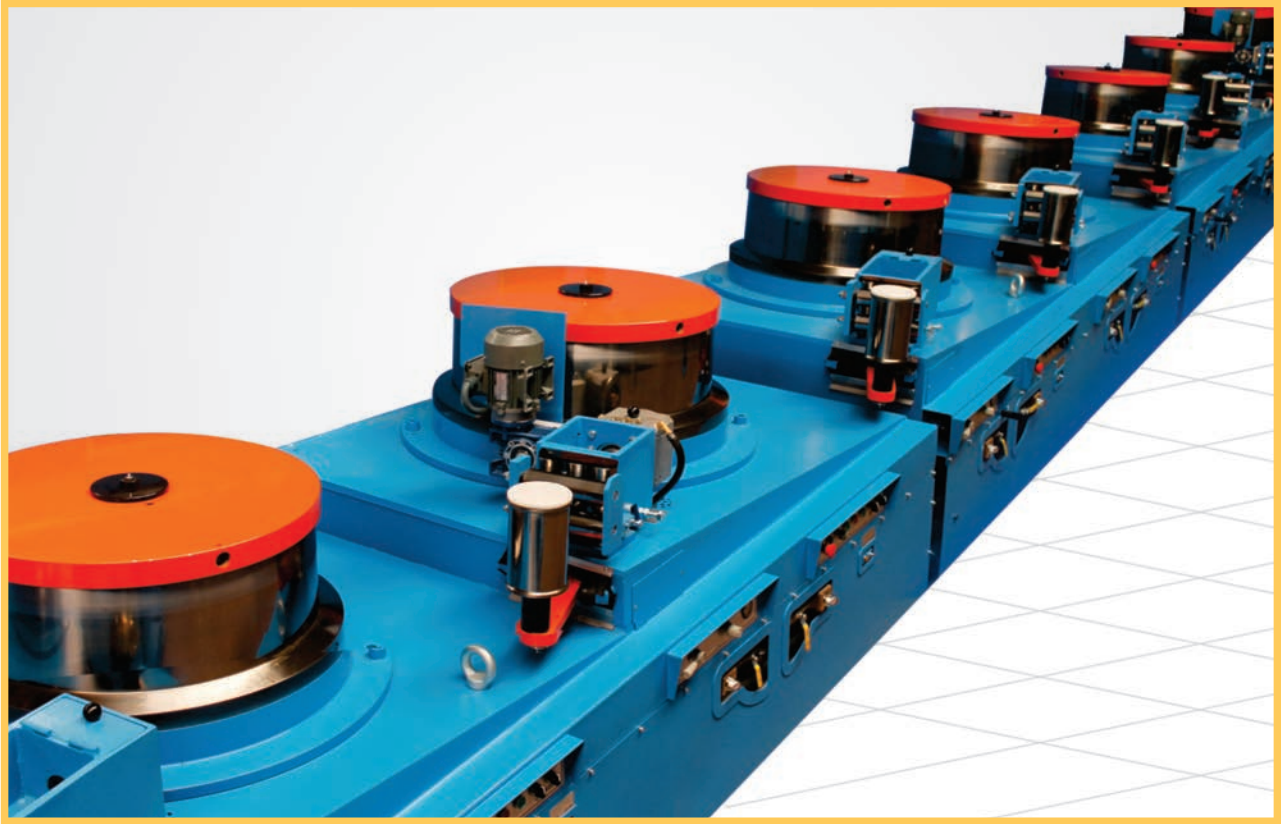

WIRE DRAWING MACHINE

Block Diameter (mm)	1200	900	800
Max Inlet Diameter (mm)	16.00	12.00	11.00
Carbon Quality	SAE 1065 - 1090	SAE 1065 - 1090	SAE 1065 - 1090
Max. Speed (m/s)	14.00	14.00	20.00

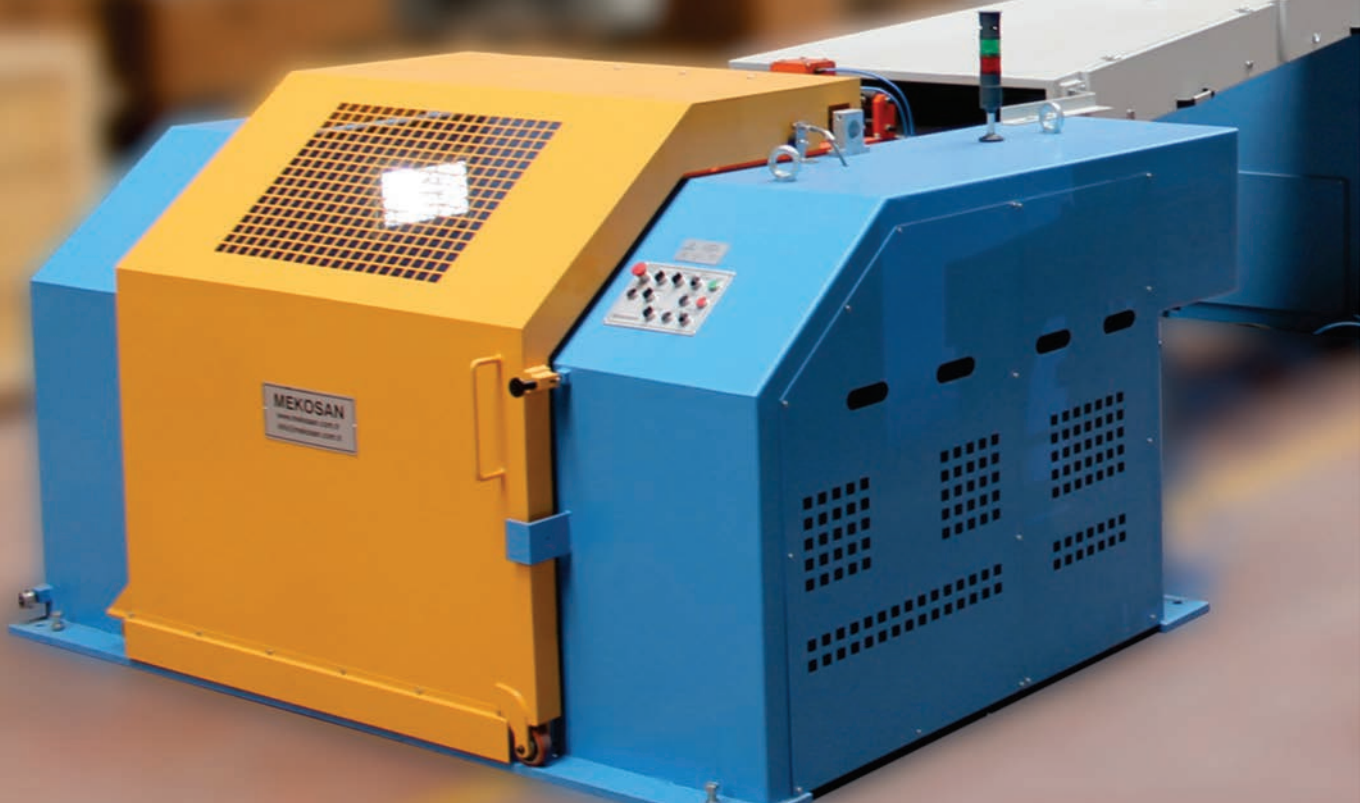

For PC Wire , PC Strand Wire , and High Tensile Strength Spring Wire.



SAE 1065 - 1090 Carbon Wire.

WIRE DRAWING MACHINE





WIRE DRAWING MACHINE



**WIRE DRAWING MACHINE
MKS-1200.9**

**HORIZONTAL SPOOLER
MKS-SPL1250**

**HORIZONTAL ROD PAY OFF
WITH COIL PUSHER
MKS-PRP**

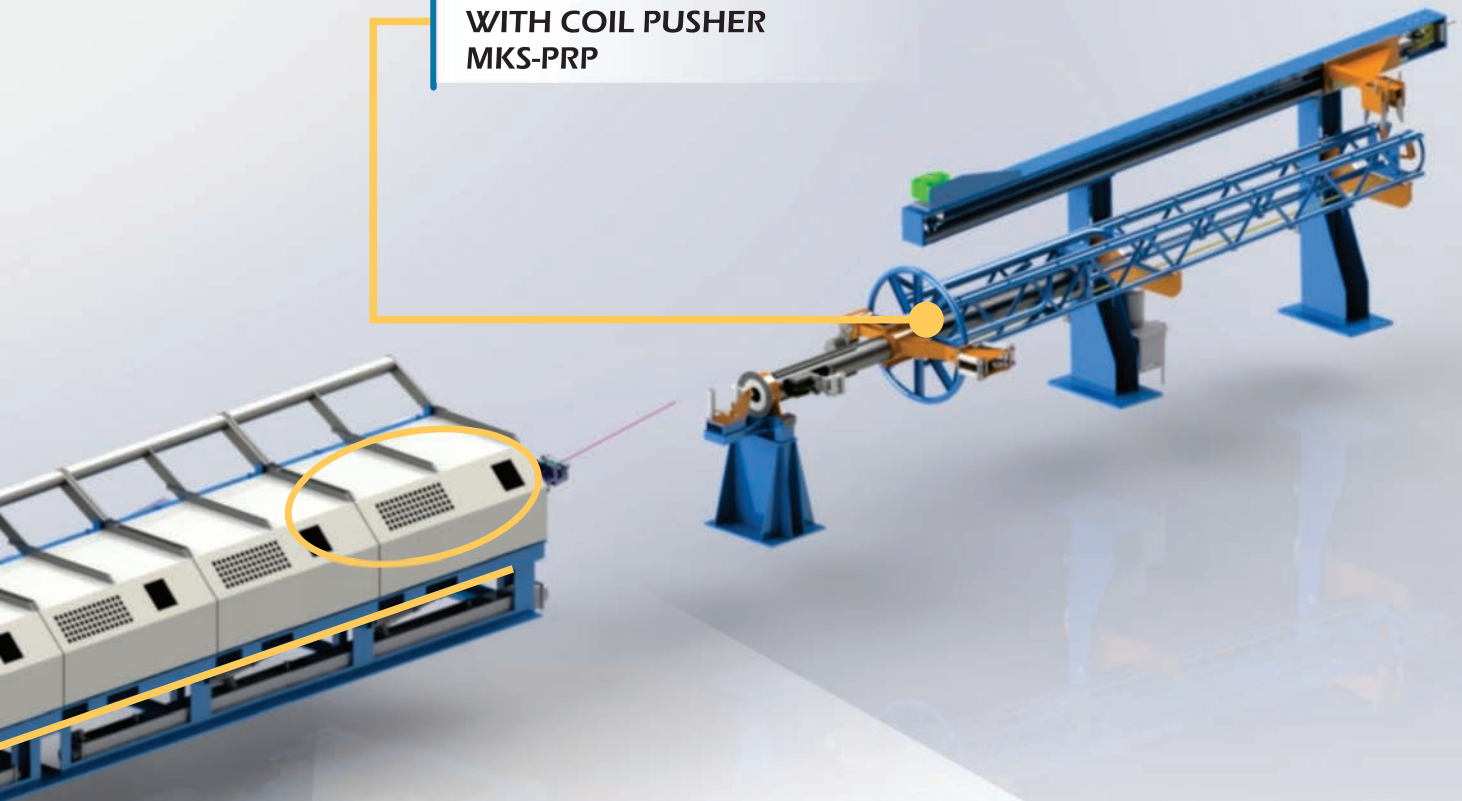

Induction Hardened Capstans

WIRE DRAWING MACHINE



Water and Air Cooling System

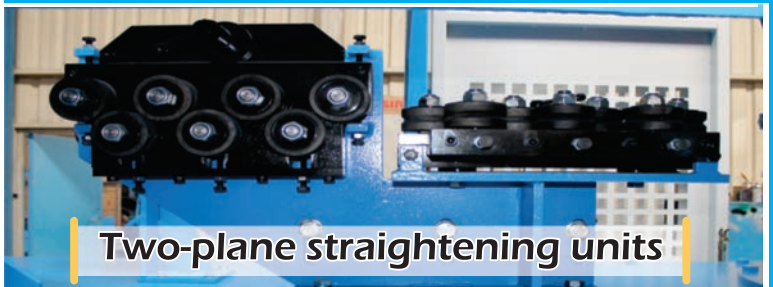
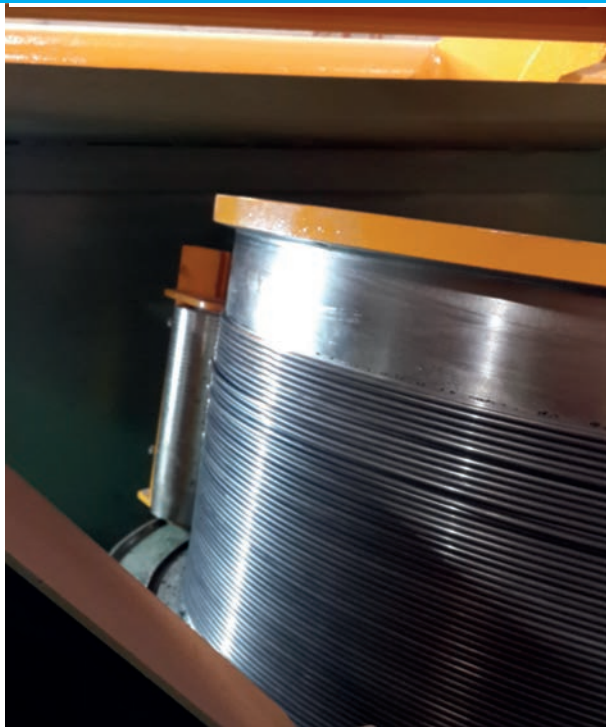

Two-plane straightening units



Water Flow Display for blocks and dies.

Easy to use control buttons.



Double deck last block with straightener

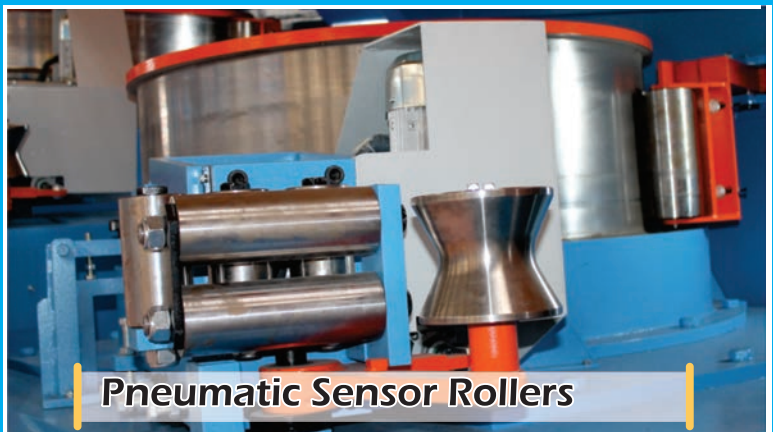

Pneumatic Sensor Rollers

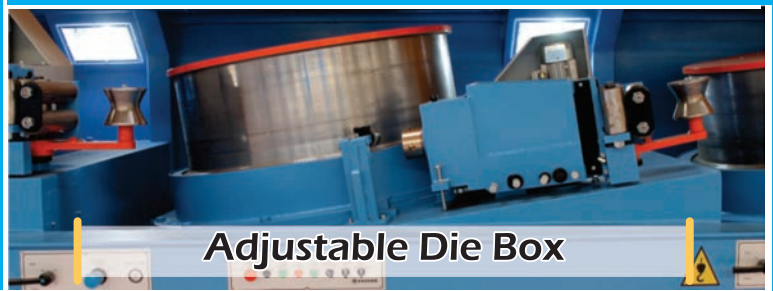

Adjustable Die Box

WIRE DRAWING MACHINE

**HORIZONTAL ROD PAY OFF
WITH COIL PUSHER
MKS-PRP**

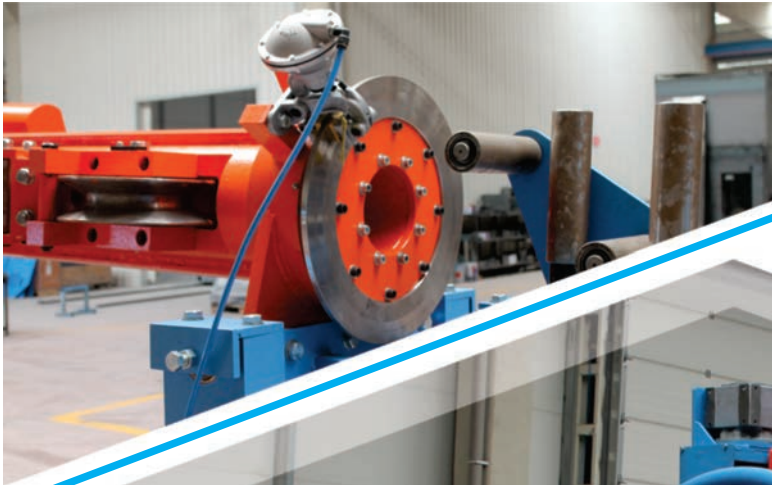

**Flyer arm to unwrap
the wire rod.**



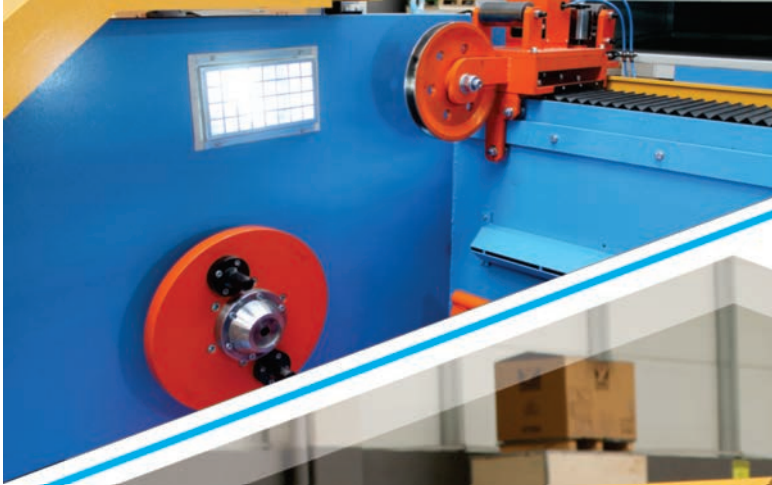

**HORIZONTAL SPOOLER
MKS-SPL1250**



**Spool pusher & Pneumatic
spool plate.**

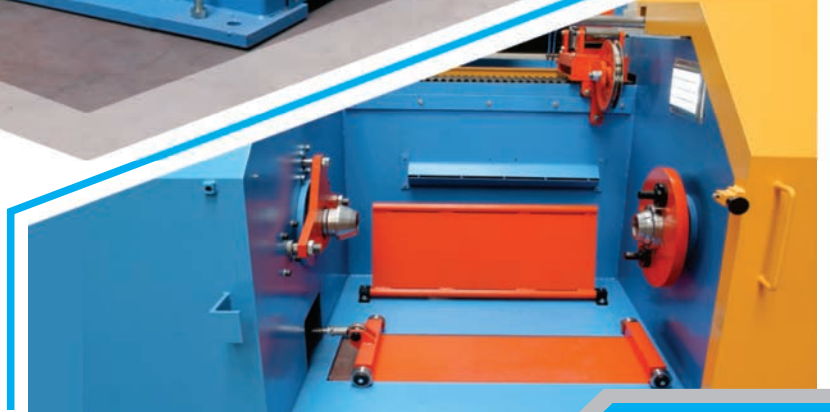

BULL BLOCK WIRE DRAWING MACHINE



**VERTICAL HYDRAULIC ROD PAY OFF
MKS-PRV**

**CASSETTE PLATFORM
MKS-CST**

**Motorized DESCALER
MKS-DSM**

DRY LUBRICANT COATING MACHINE
MKS-LUB

VERTICAL SPOOLER
MKS-SPLV

WIRE STRESS RELIEVING DEVICE
MKS-DRSJ

BULL BLOCK
MKS-BL710

CASSETTE PLATFORM
MKS-CST

- High Speed .
- Cassette System .
- Used For Mesh Wire .
- Ribbed & Smooth Wire .

BULL BLOCK WIRE DRAWING MACHINE



**VERTICAL HYDRAULIC
ROD PAY OFF
MKS-PRV**





**Motorized DESCALER
MKS-DSM**

BULL BLOCK WIRE DRAWING MACHINE

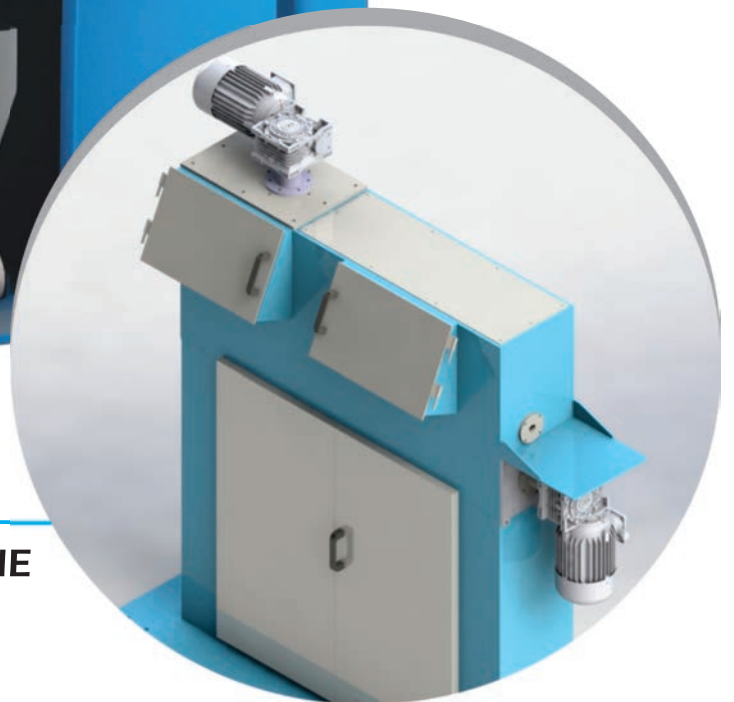

**DRY LUBRICANT COATING MACHINE
MKS-LUB**

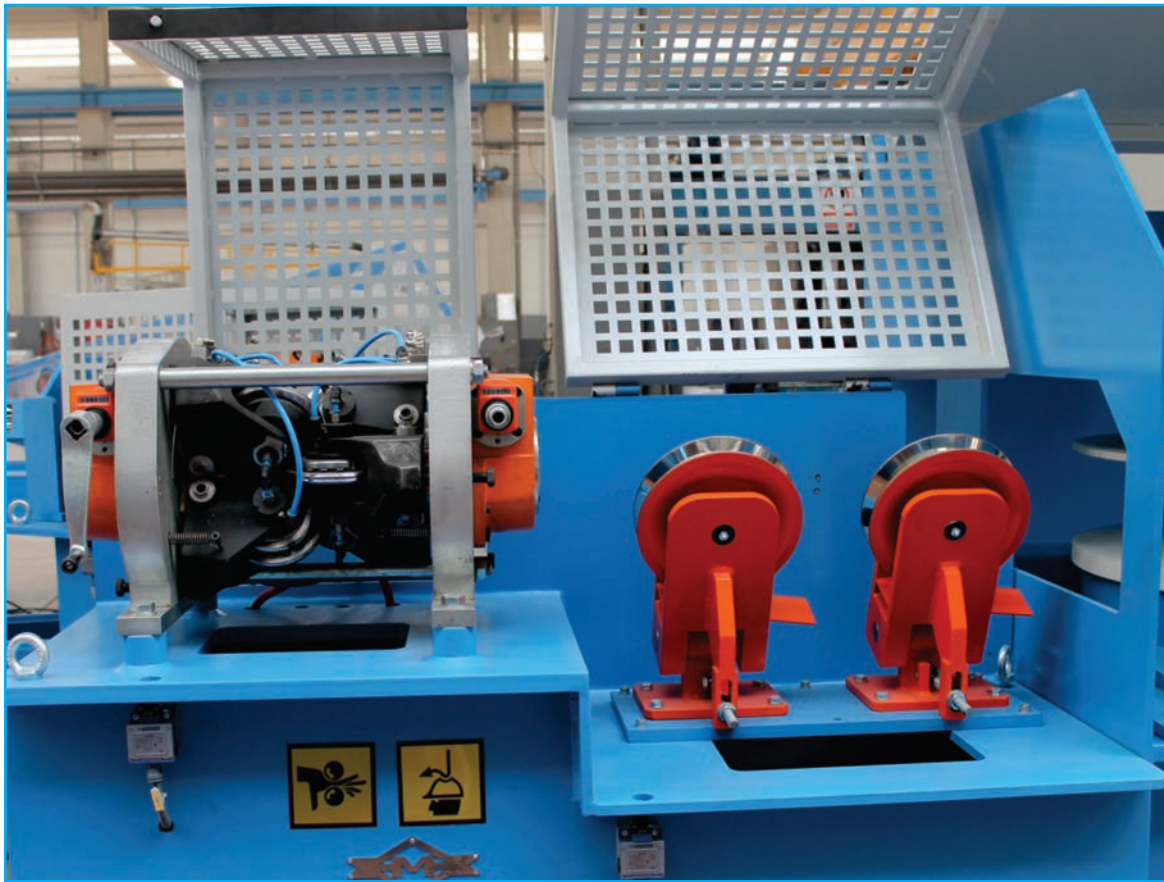

CASSETTE PLATFORM MKS-CST

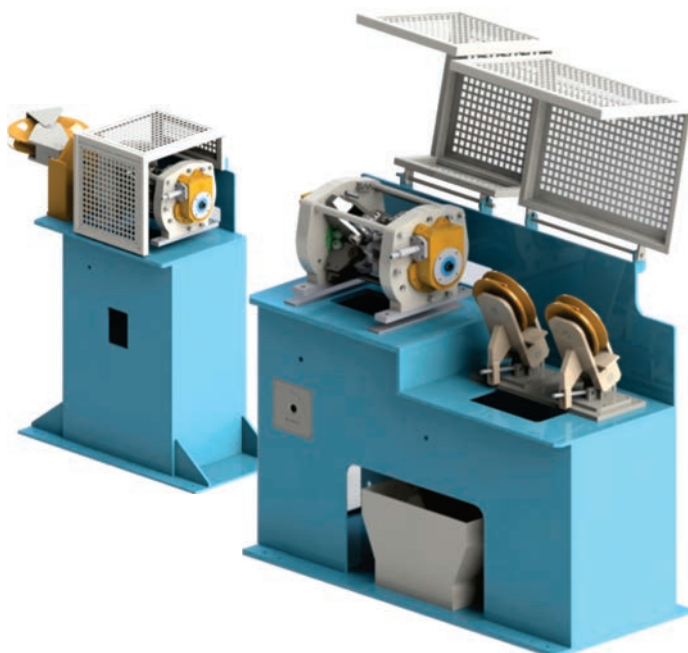

	FIRST CASSETTE			SECOND CASSETTE			
	INITIAL DIA	OVAL REDUCING	ROUND REDUCING	WIRE EXIT FORM 1st CASSETTE	FORMING	FINAL O PROFILING	OUTLET DIA
1	5.5 mm	RO 1	RT 1	4.40 mm	FO 1	PR 4.0	4.0 mm
2	5.5 mm	RO 1	RT 1	5.05 mm	FO 1	PR 4.5	4.5 mm
3	6.0 mm	RO 2	RT 2	5.60 mm	FO 1	PR 5.0	5.0 mm
4	7.0 mm	RO 2	RT 2	6.15 mm	FO 1	PR 5.5	5.5 mm
5	7.5 mm	RO 3	RT 3	6.70 mm	FO 2	PR 6.0	6.0 mm
6	8.0 mm	RO 3	RT 3	7.25 mm	FO 2	PR 6.5	6.5 mm
7	8.5 mm	RO 4	RT 4	7.85 mm	FO 2	PR 7.0	7.0 mm
8	9.0 mm	RO 4	RT 4	8.40 mm	FO 3	PR 7.5	7.5 mm
9	10.0 mm	RO 5	RT 5	8.85 mm	FO 3	PR 8.0	8.0 mm
10	11.0 mm	RO 5	RT 5	9.50 mm	FO 3	PR 8.5	8.5 mm
11	11.0 mm	RO 5	RT 5	10.1 mm	FO 3	PR 9.0	9.0 mm
12	12.0 mm	RO 6	RT 6	10.6 mm	FO 4	PR 9.5	9.5 mm

BULL BLOCK WIRE DRAWING MACHINE

**BULL BLOCK
MKS-BL710**



**WIRE STRESS
RELIEVING DEVICE
MKS-DRSJ**

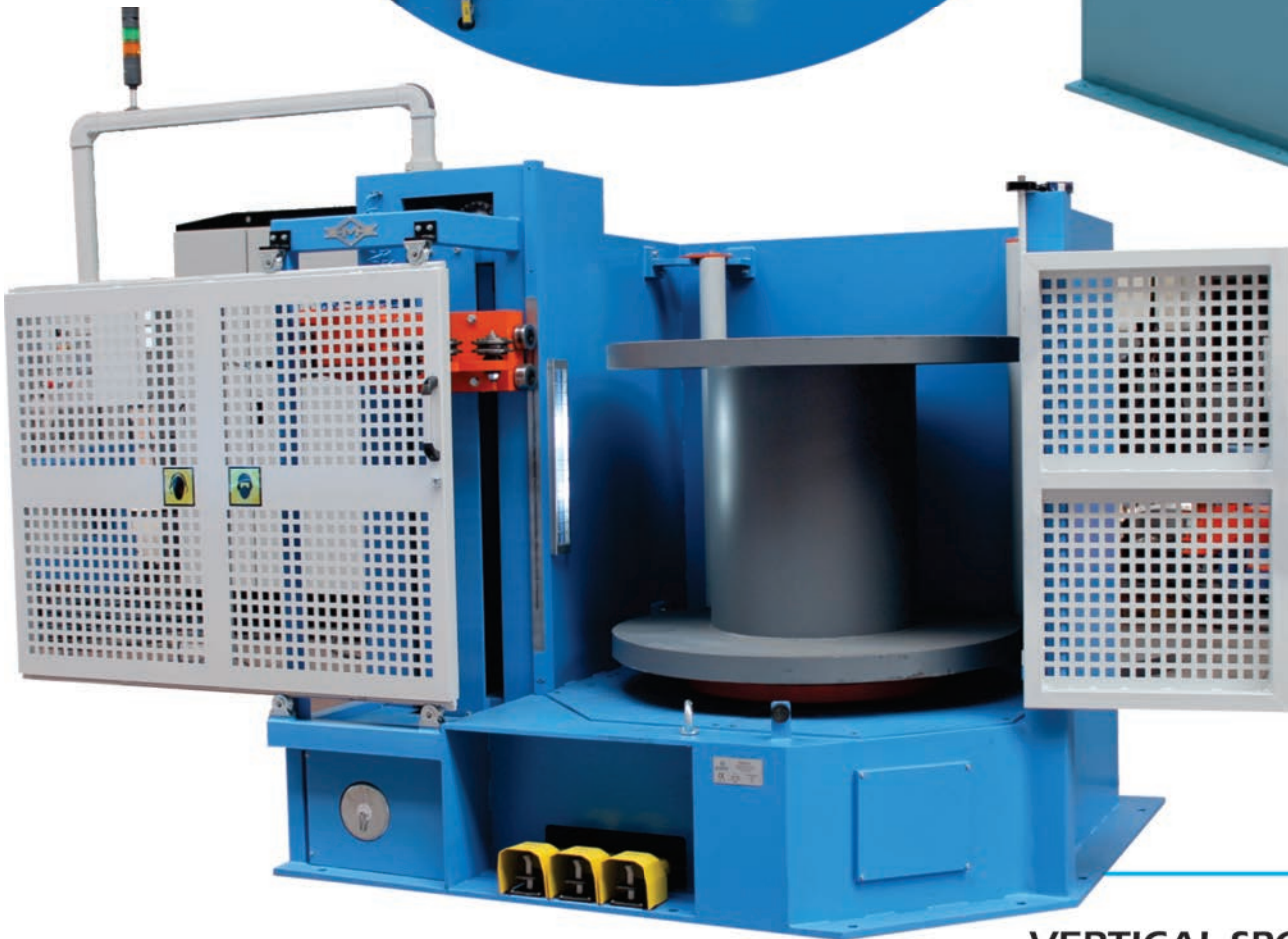
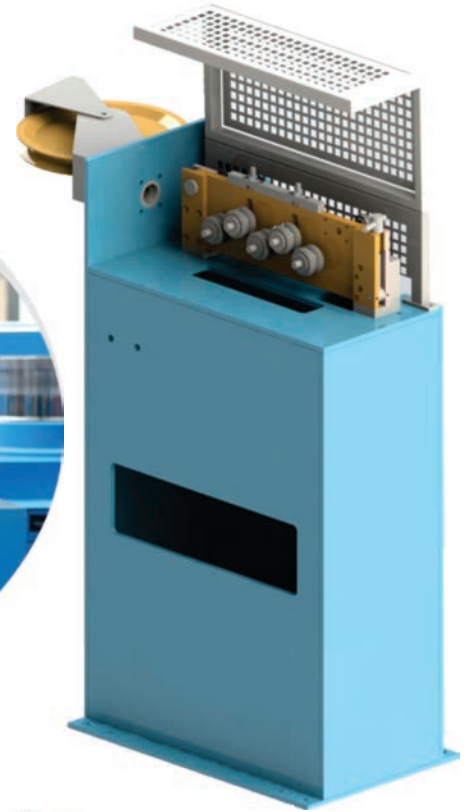
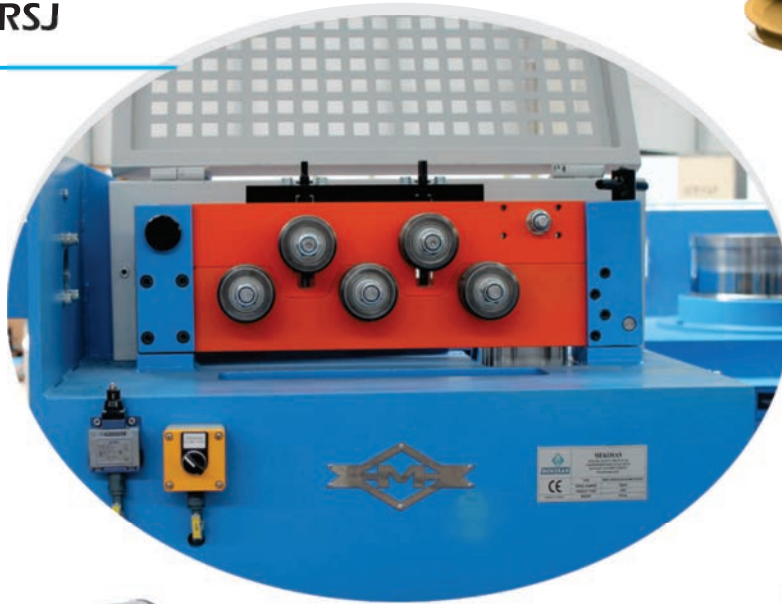

**VERTICAL SPOOLER
MKS-SPLV**

HANDSTAND TYPE MONO BLOCK WIRE DRAWING MACHINE



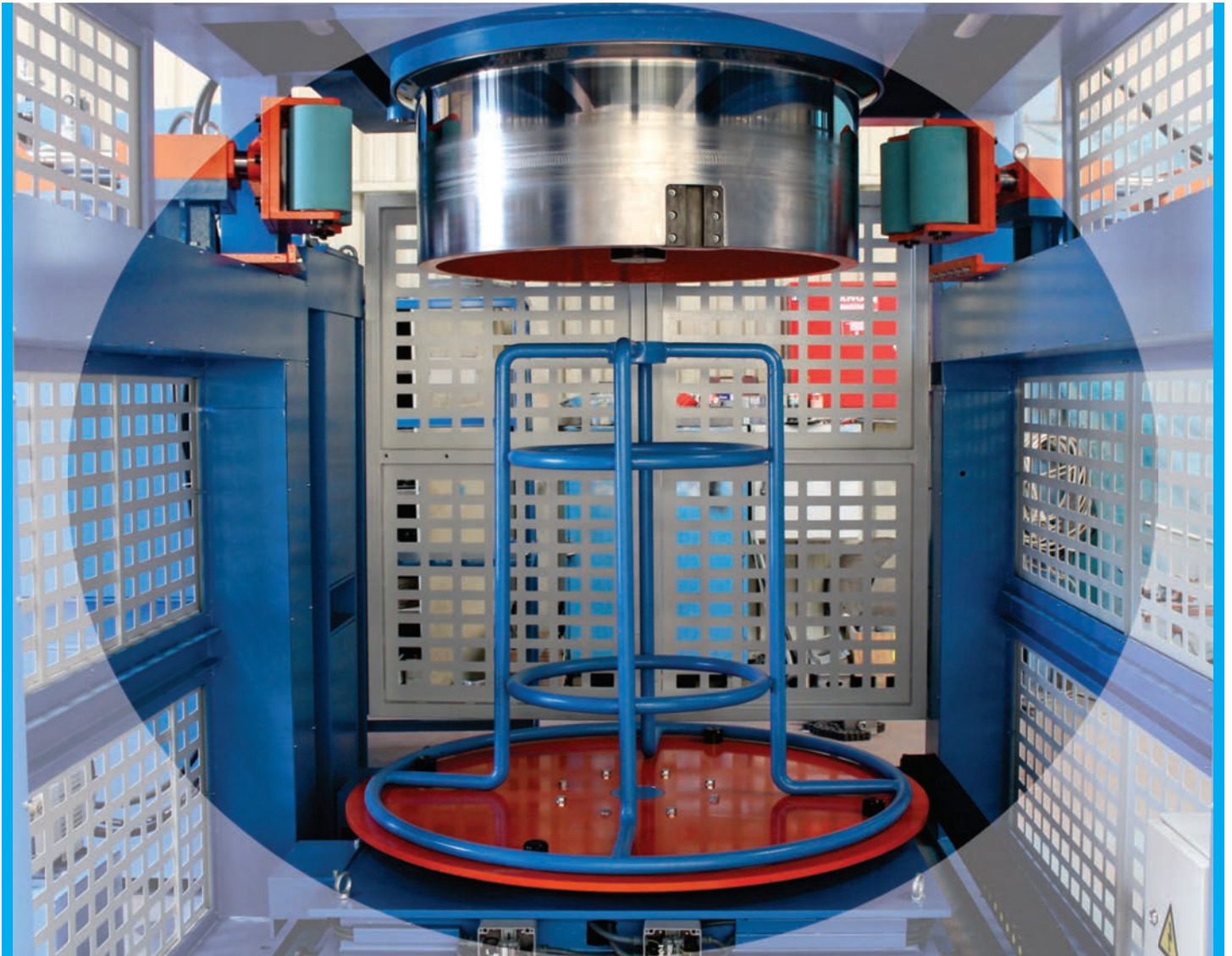

Block Diameter	800 mm	900 mm	1000 mm	1200 mm
Max Inlet Diameter	12 mm	16 mm	22 mm	28 mm

HANDSTAND TYPE MONO BLOCK WIRE DRAWING MACHINE

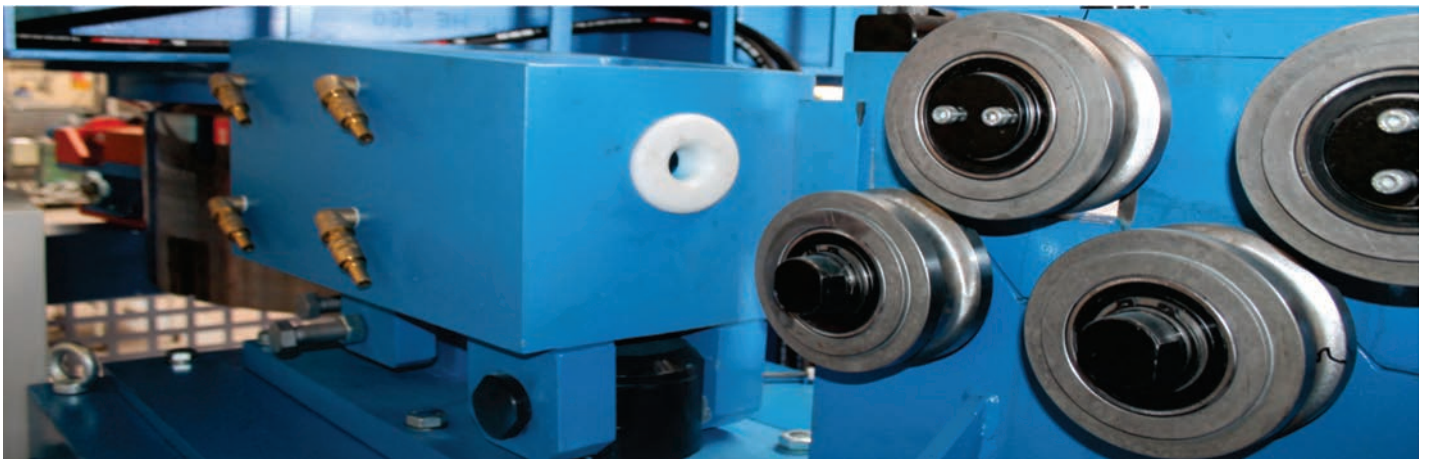
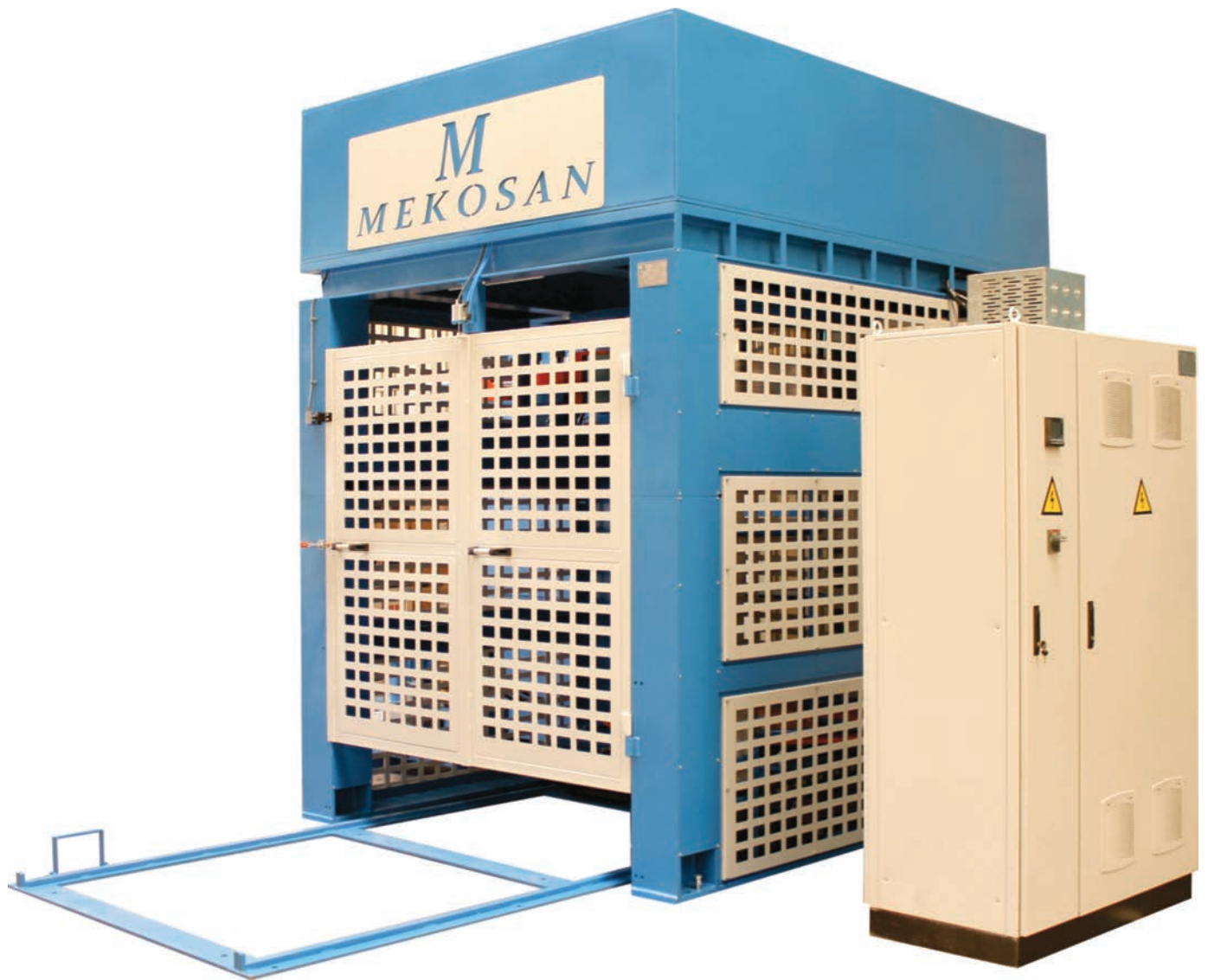

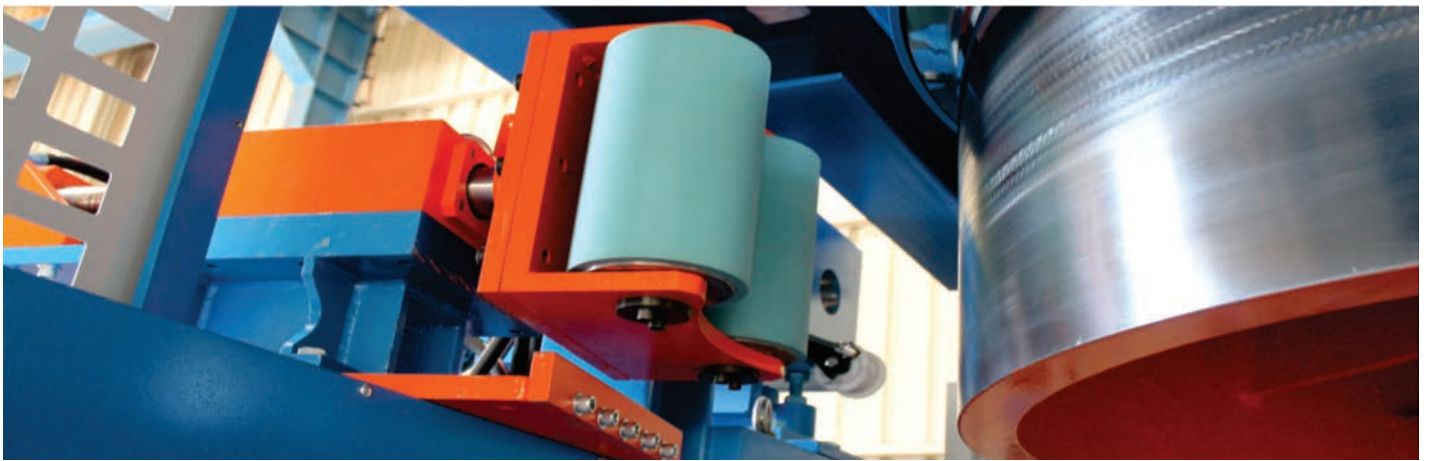
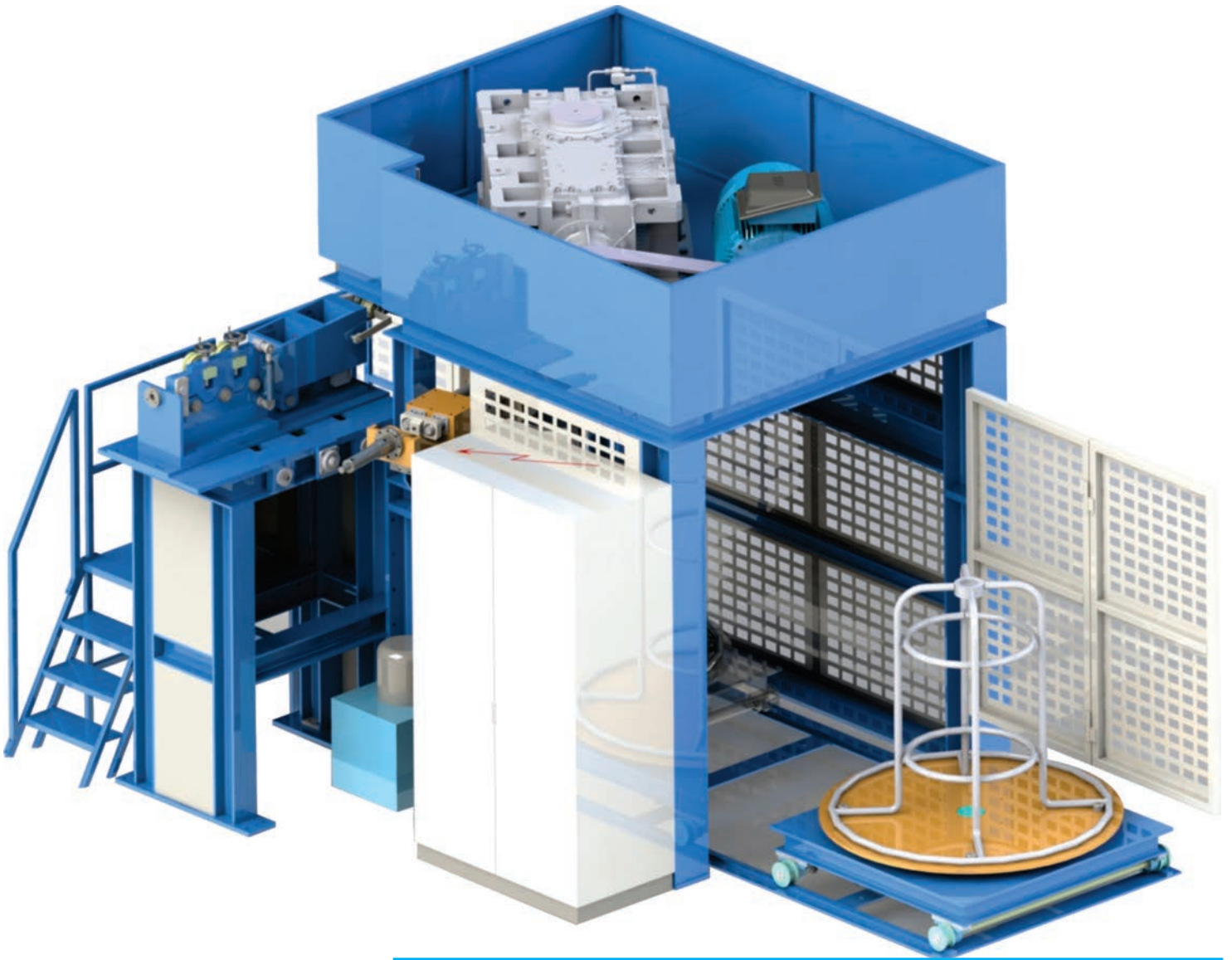

WET WIRE DRAWING MACHINE

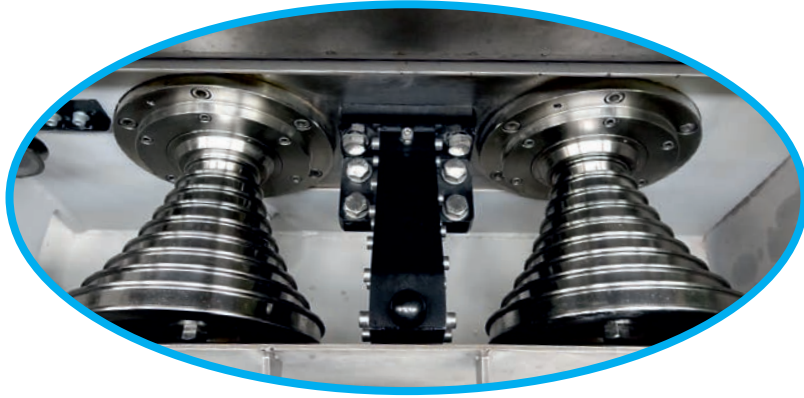

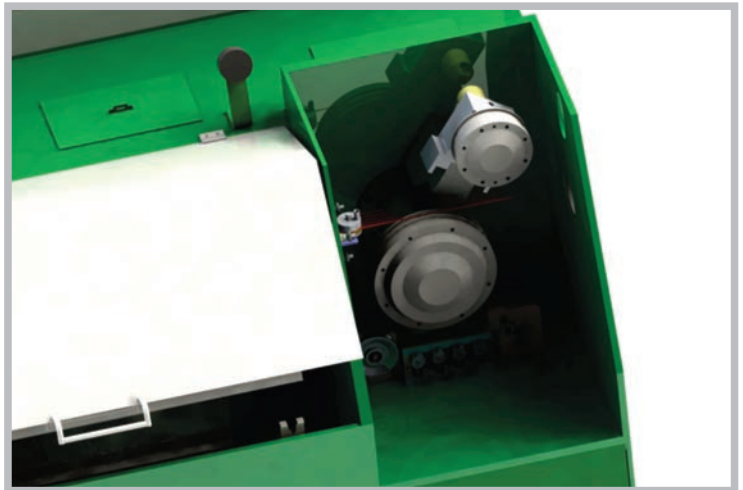
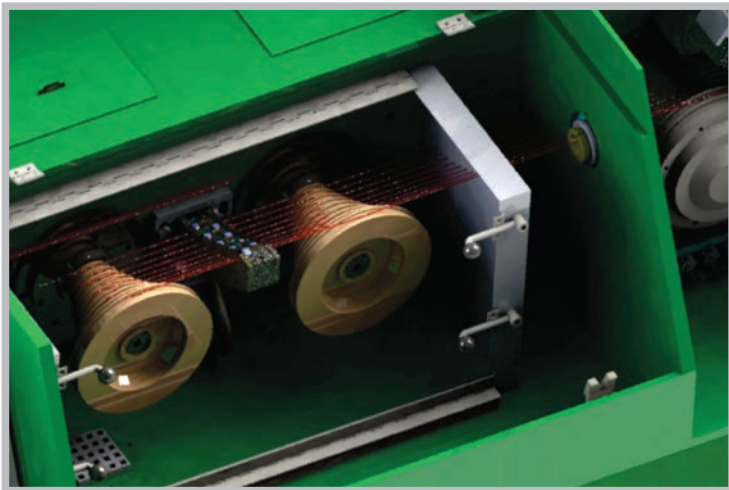
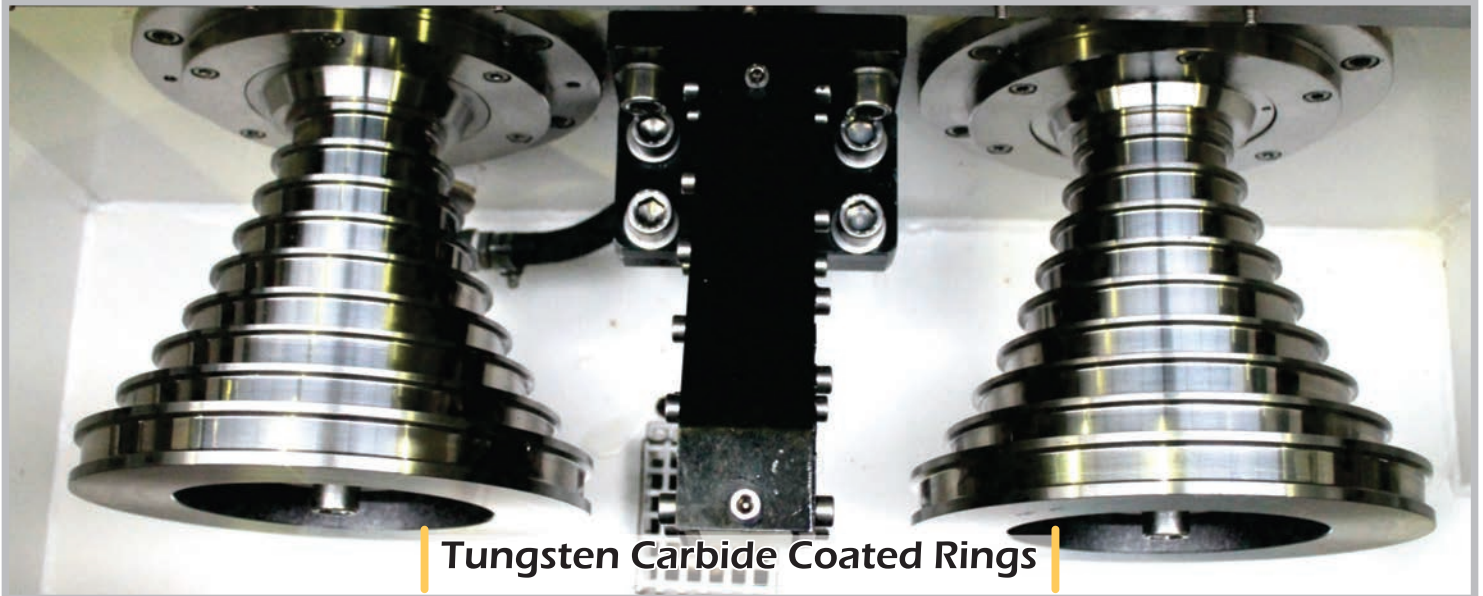
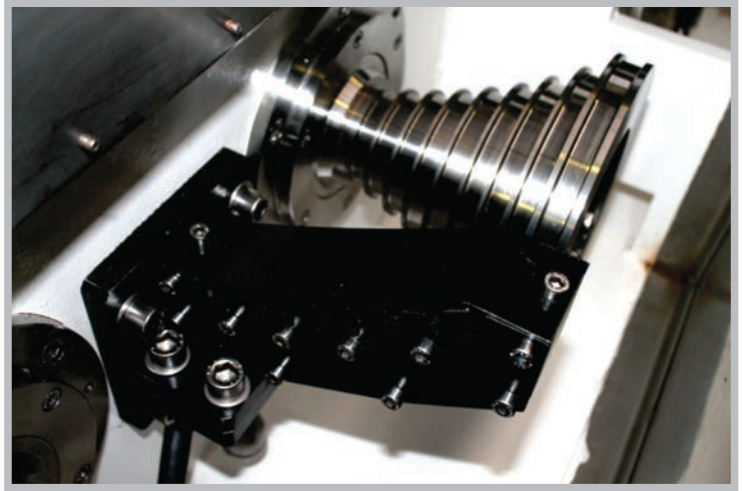
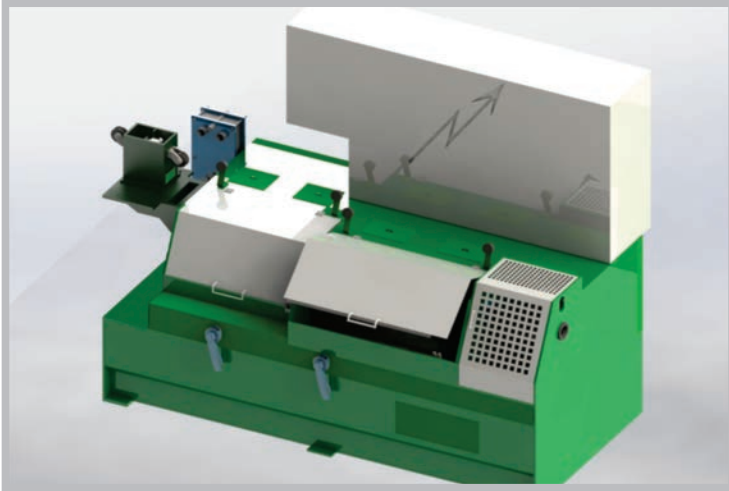

WET WIRE DRAWING MACHINE

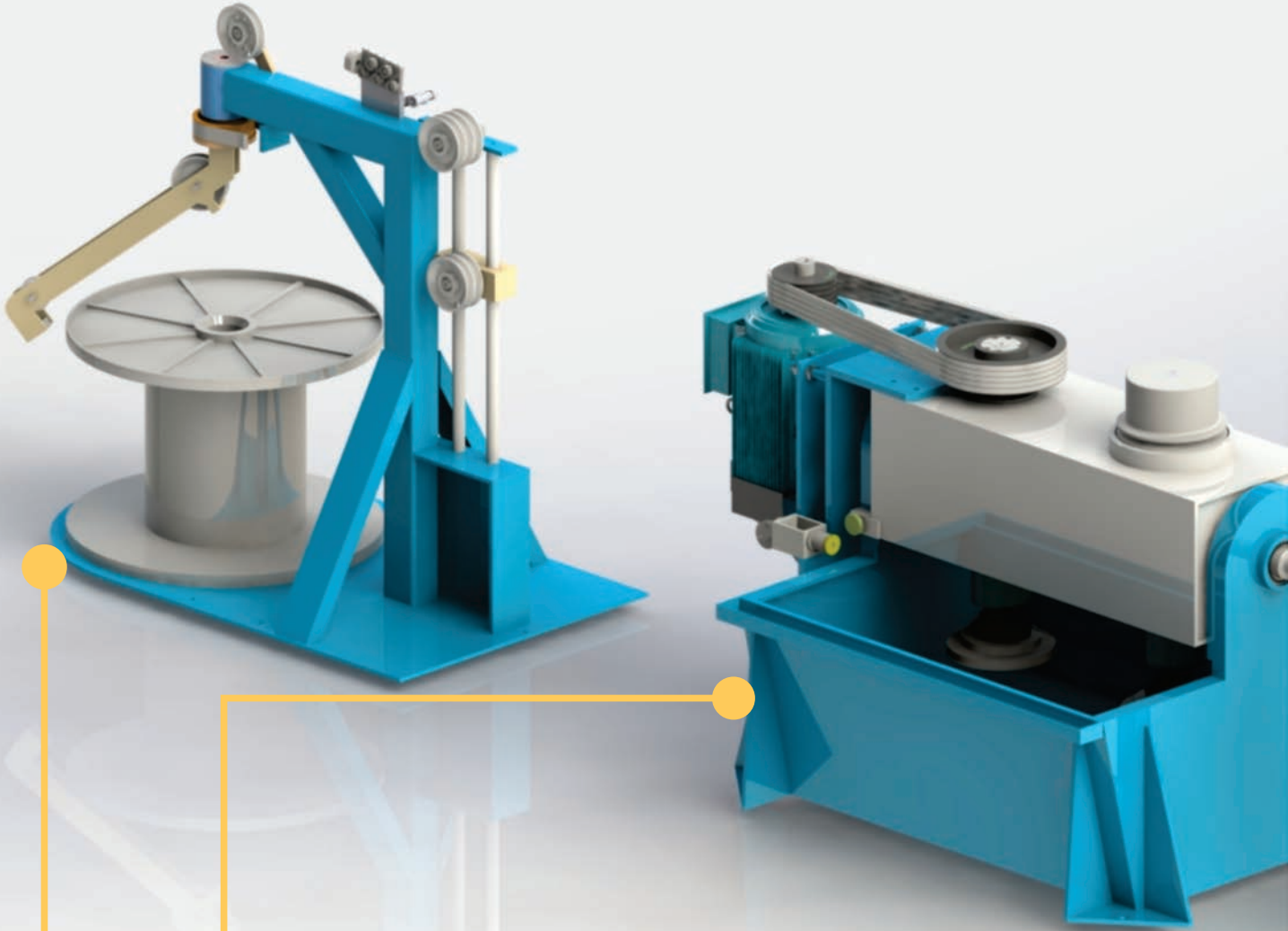

**WET WIRE DRAWING MACHINE
MKS-WET**

**FLYER PAY OFF
MKS-FLS**

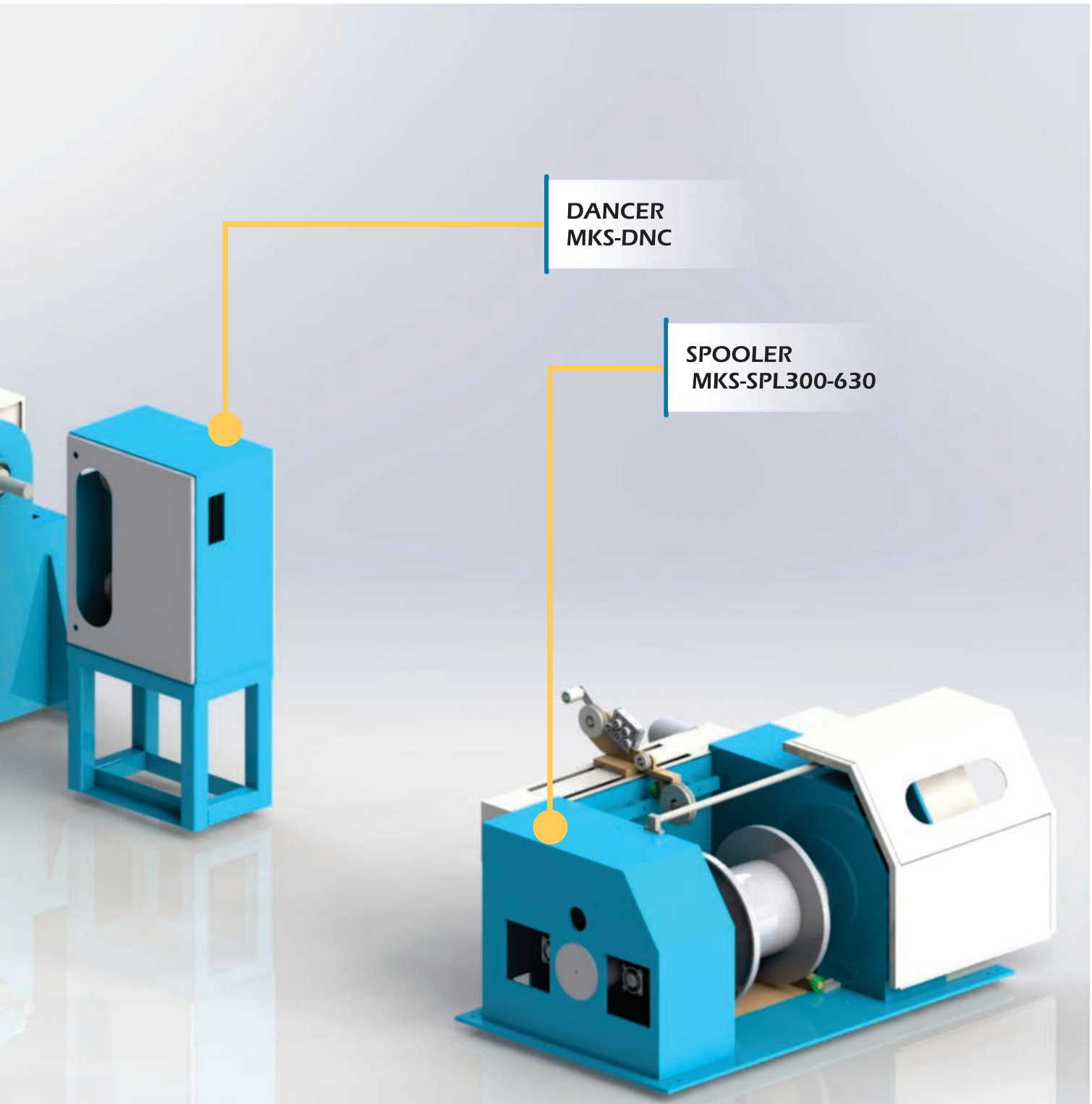

**DANCER
MKS-DNC**

**SPOOLER
MKS-SPL300-630**

WET WIRE DRAWING MACHINE

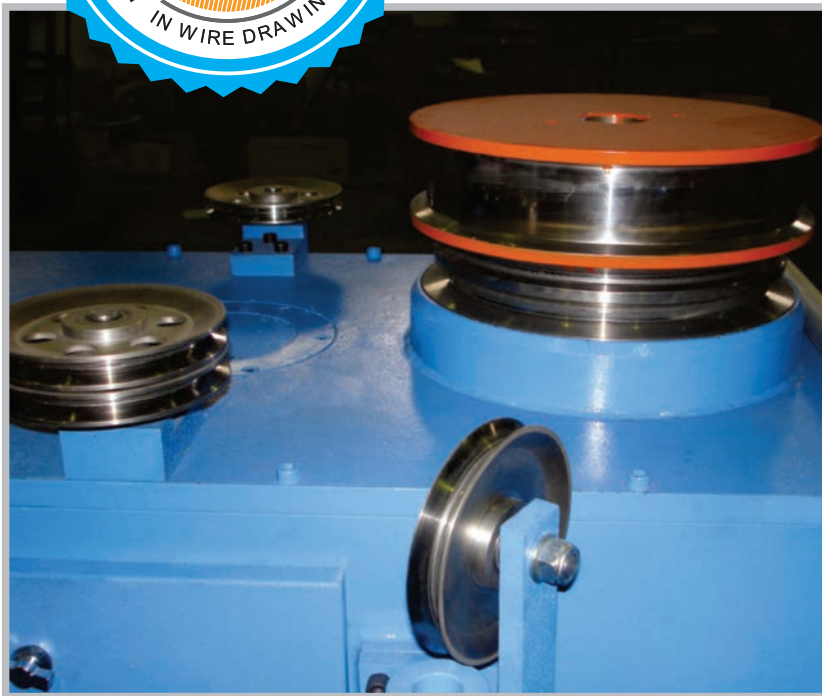

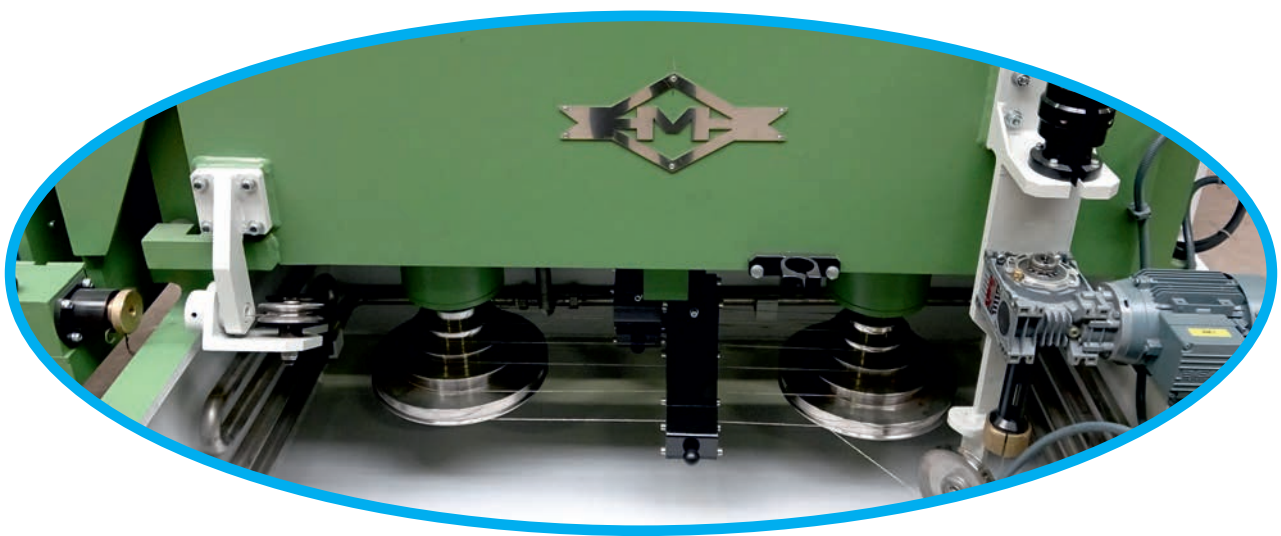



VERTICAL PAY OFF MKS-PRV



PAY-OFF



VERTICAL PAY OFF MKS-PRV



PAY-OFF



**HORIZONTAL ROD PAY-OFF
WITH COIL PUSHER MKS-PRP**



PAY-OFF



Flyer arm to unwrap the wire rod

HORIZONTAL ROD PAY-OFF WITH COIL PUSHER



MEKOSAN

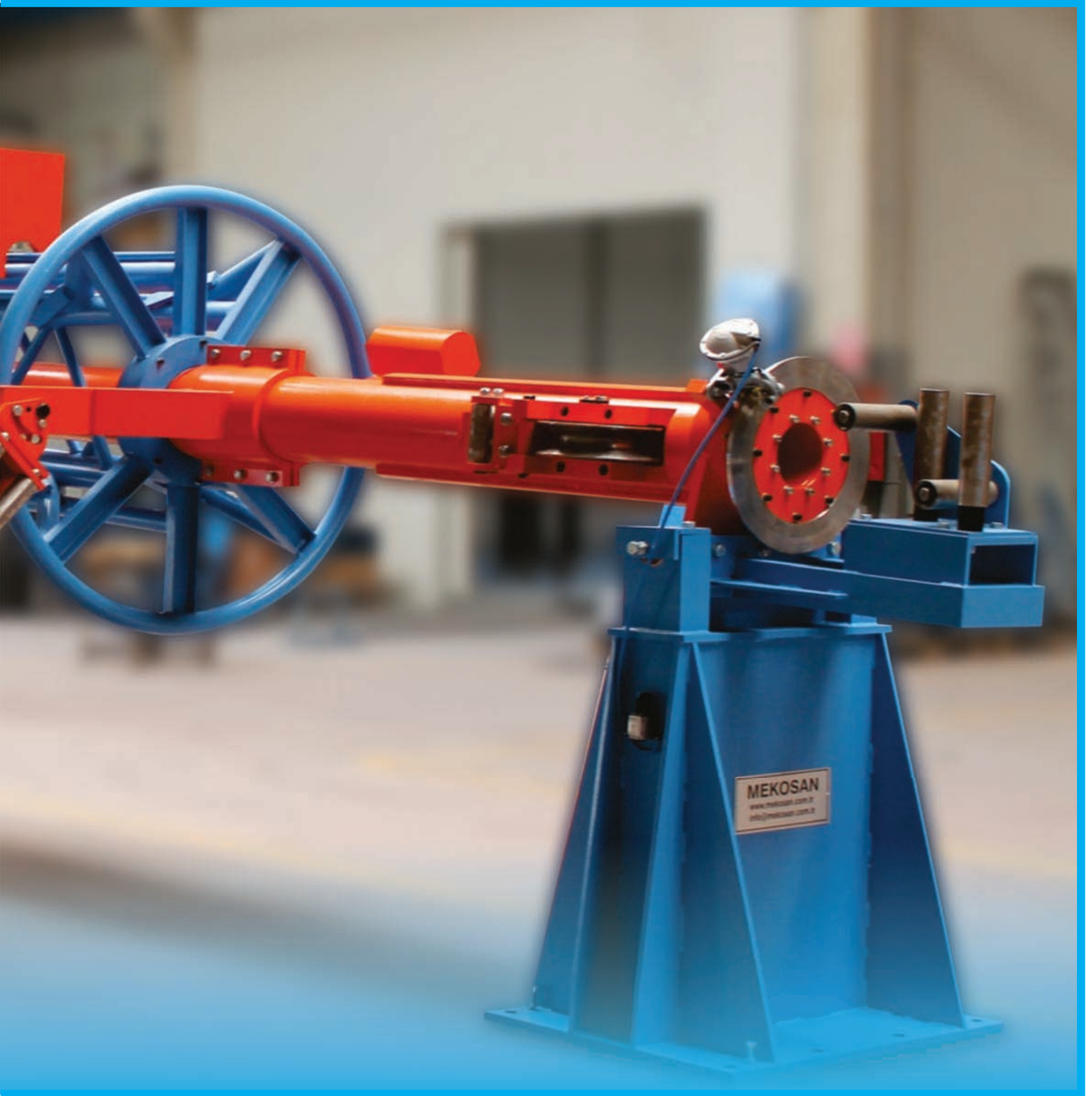

PAY-OFF

HORIZONTAL ROTATING ROD PAY OFF MKS-PRR

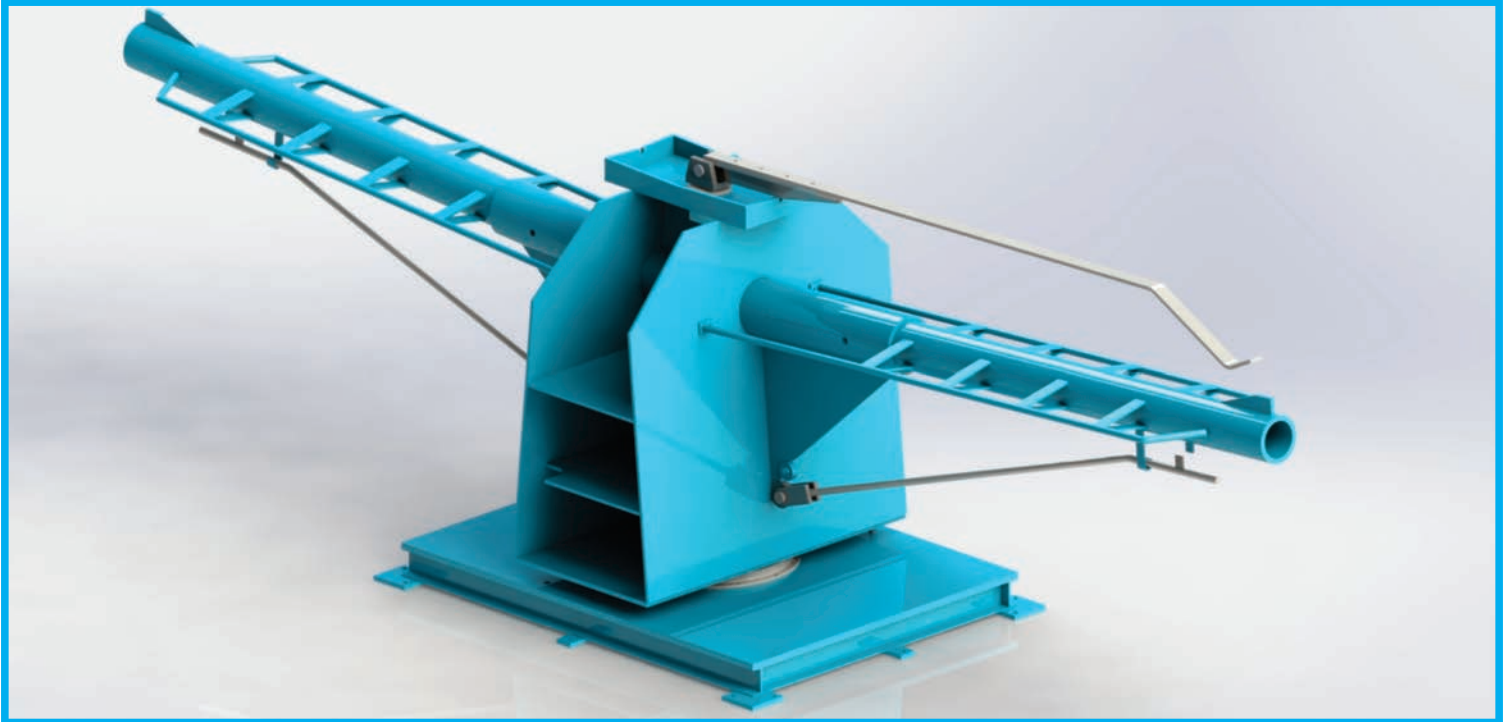

HORIZONTAL STATIC ROD PAY OFF MKS-PRS

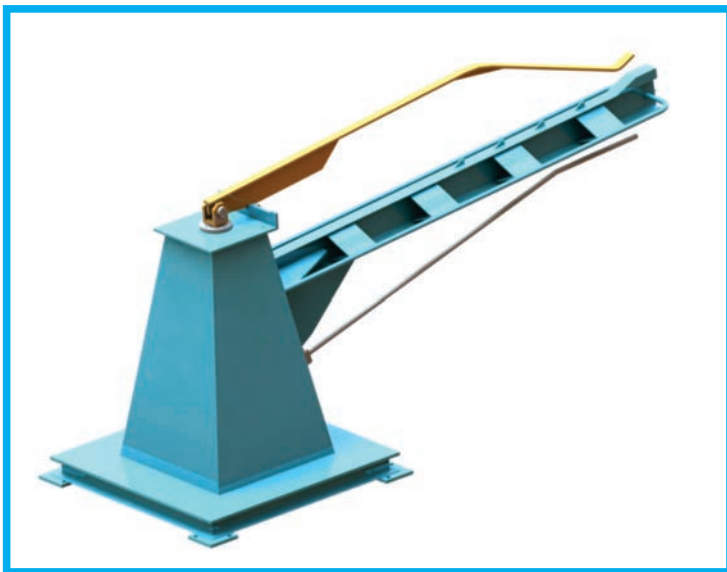

PAY-OFF

MOTORIZED PAY OFF MKS-PMR

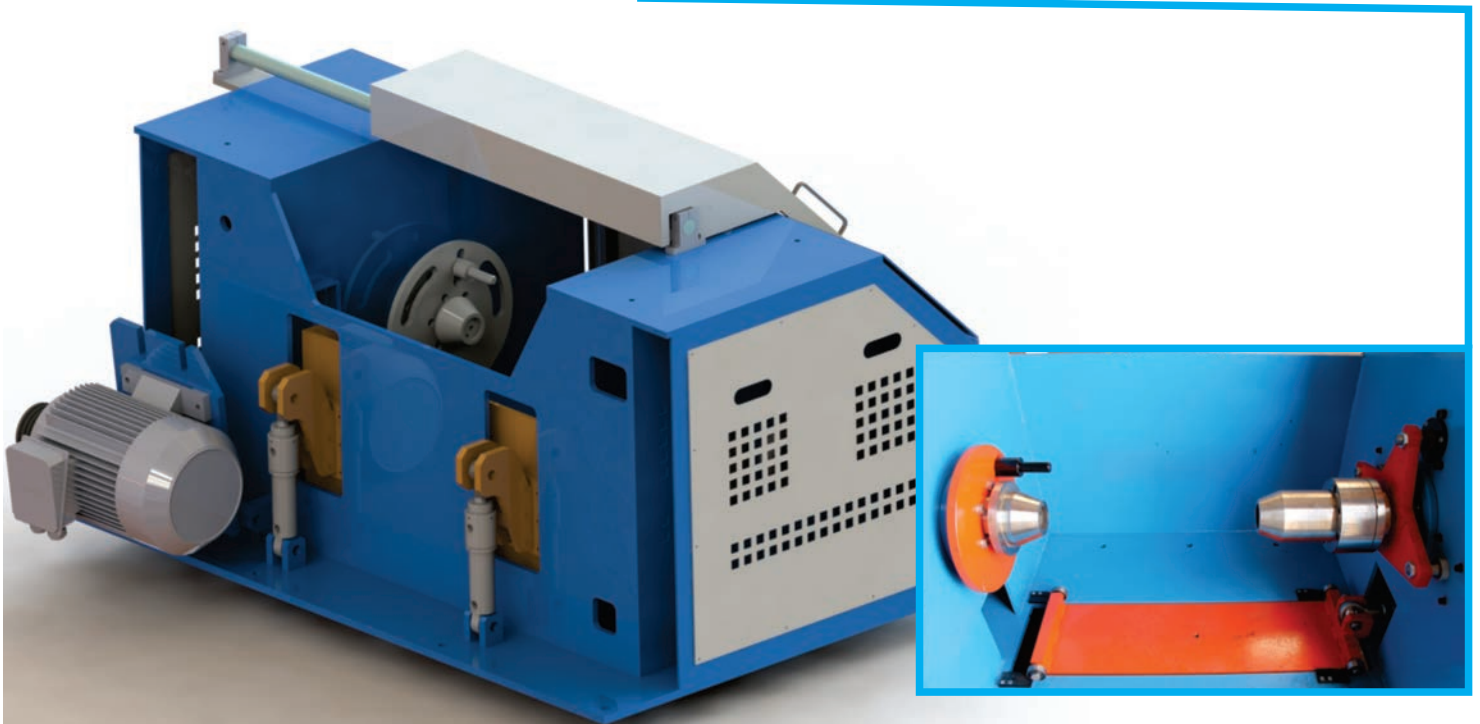

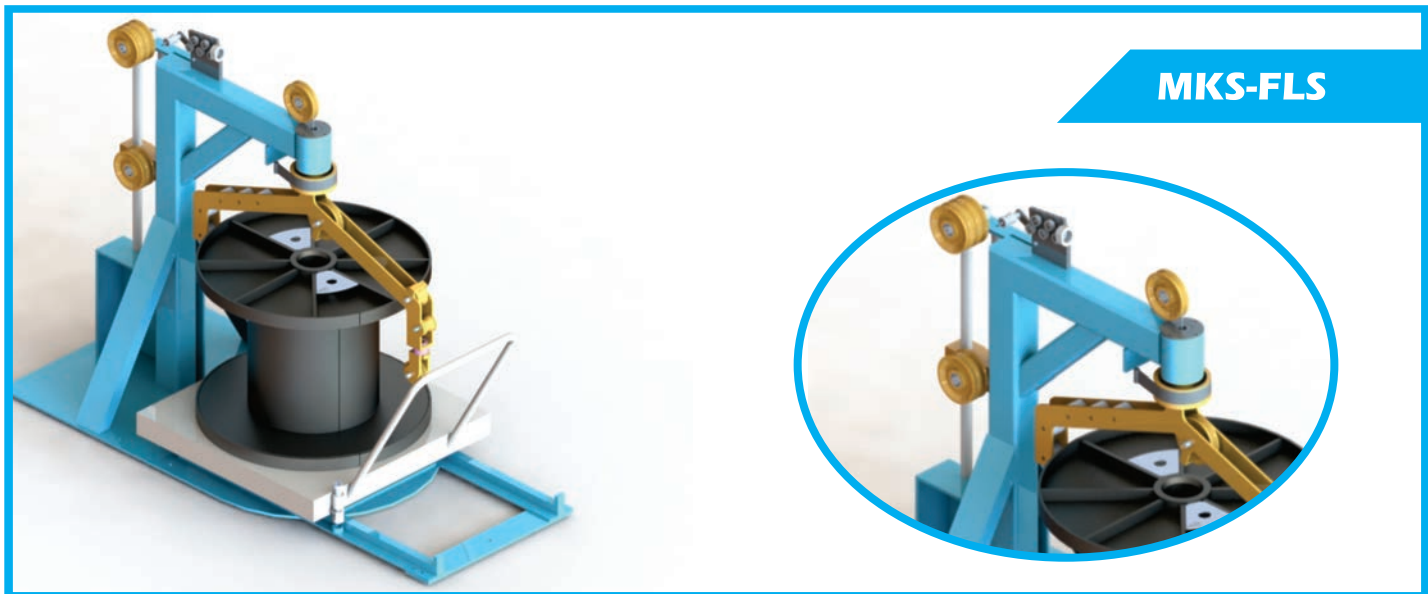
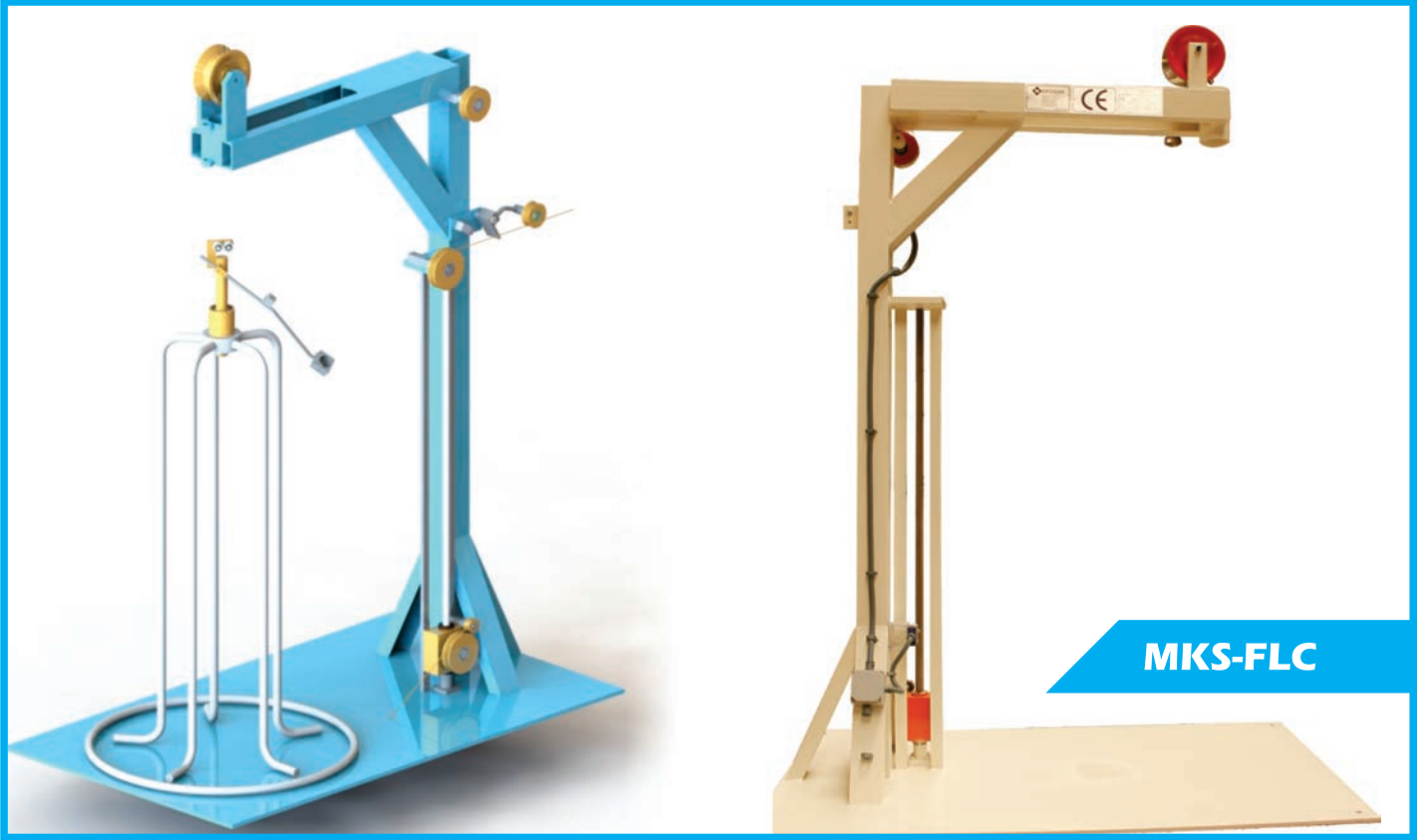

PAY-OFF

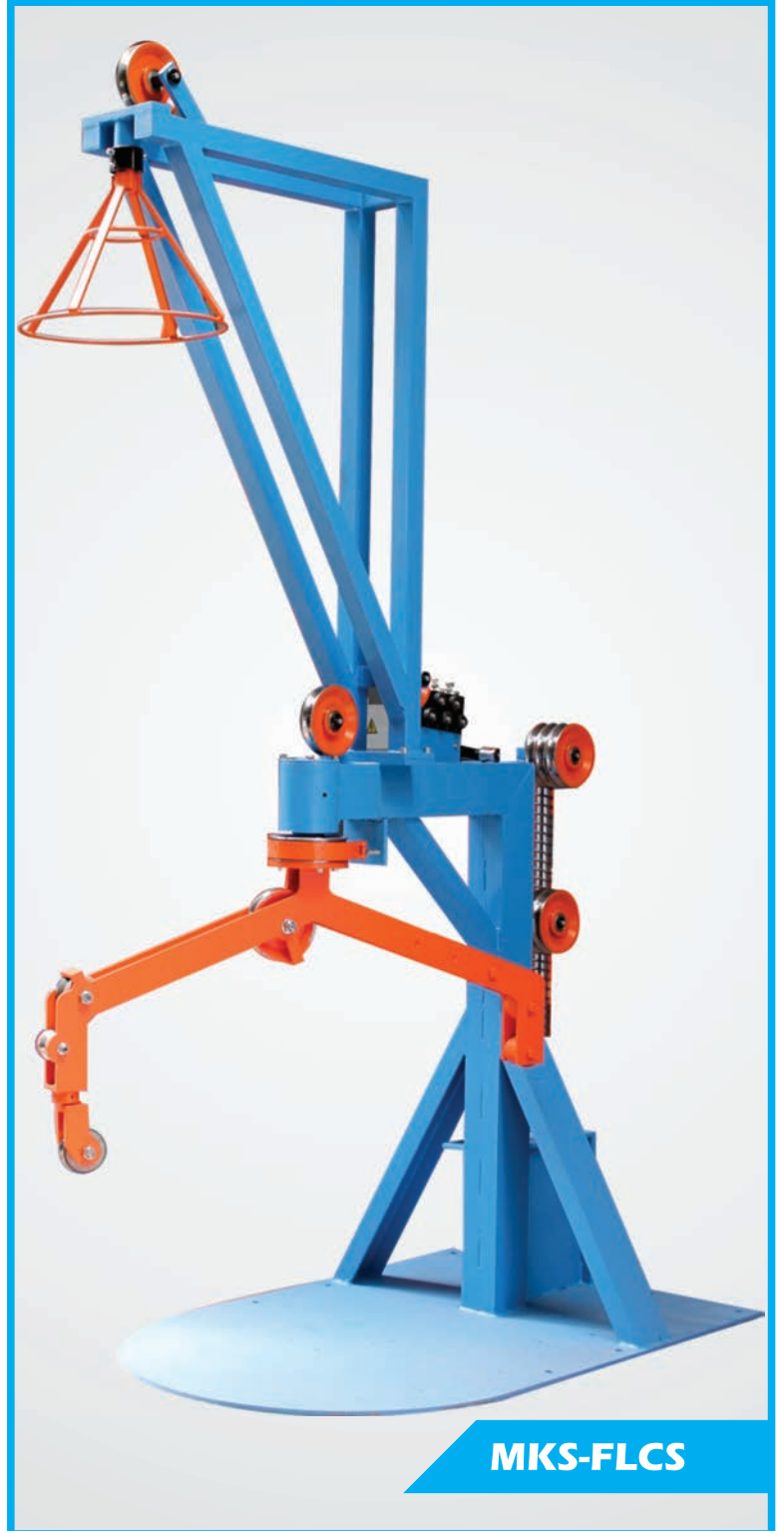

MKS-FLCS

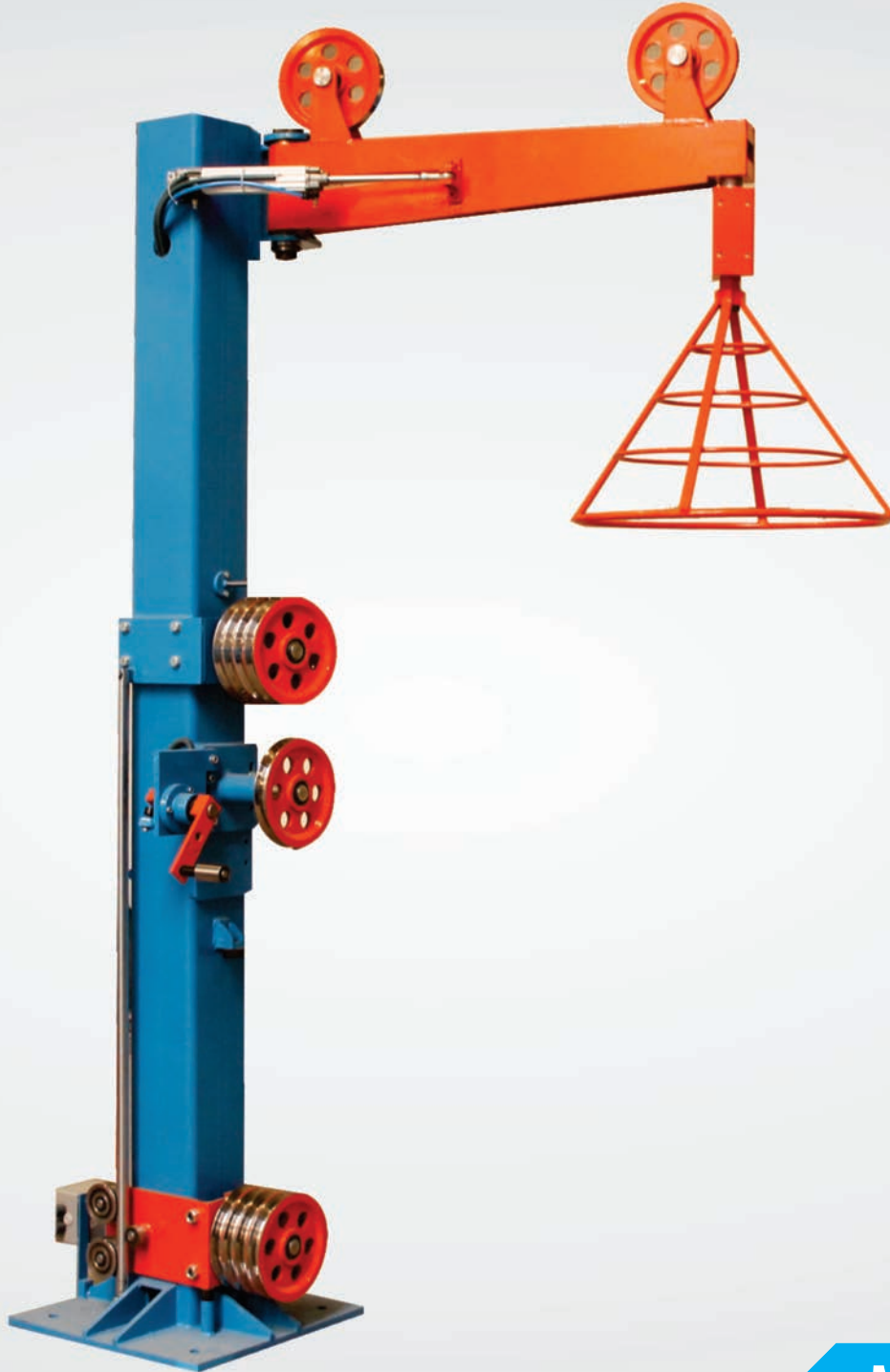

MKS-FLR

COILER

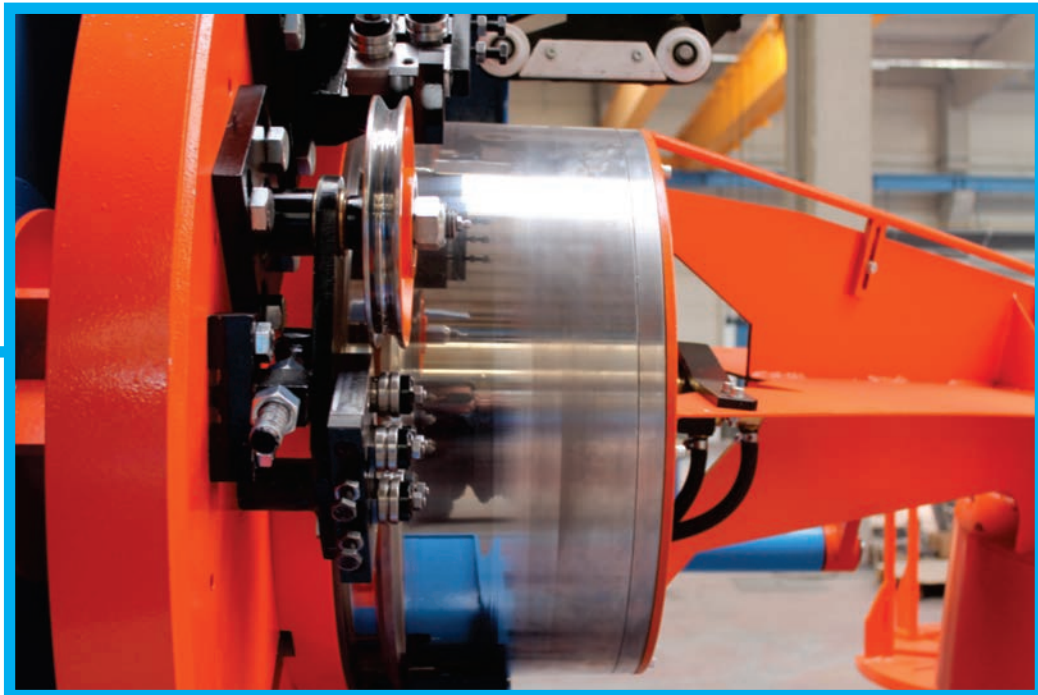
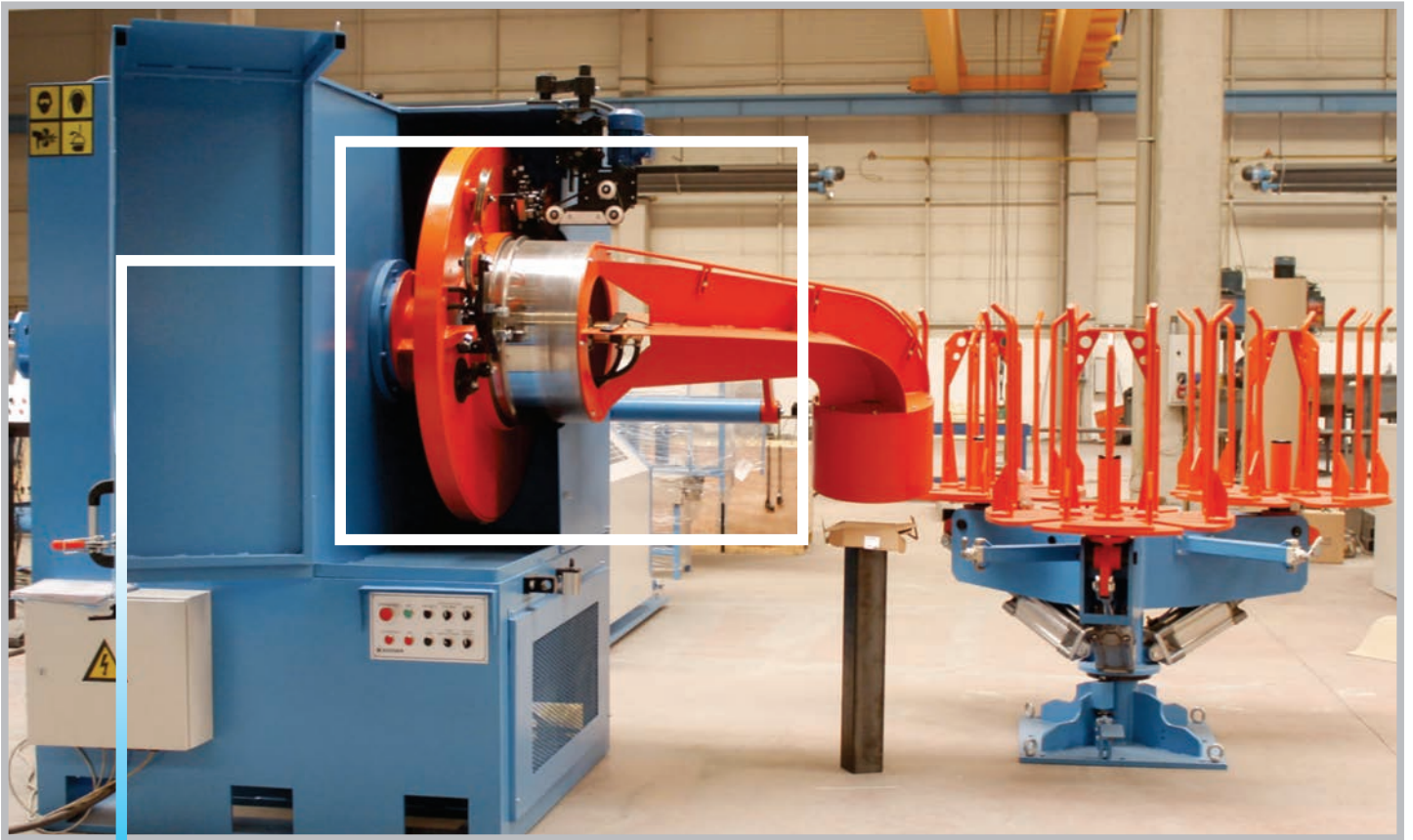

COILER WITH CAROUSEL TABLE MKS-CLR

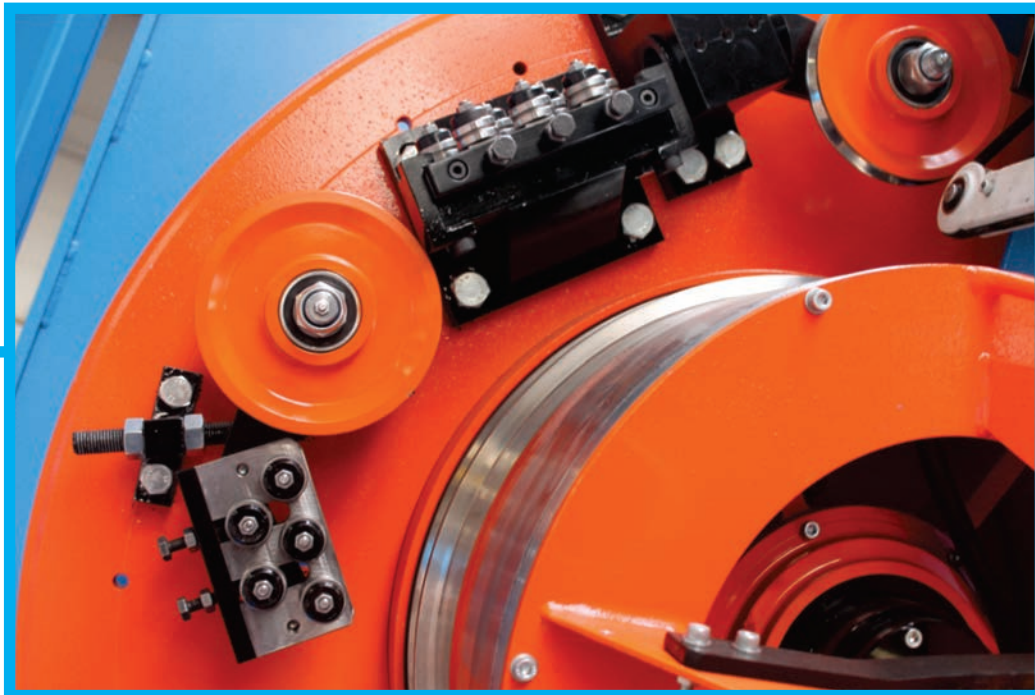
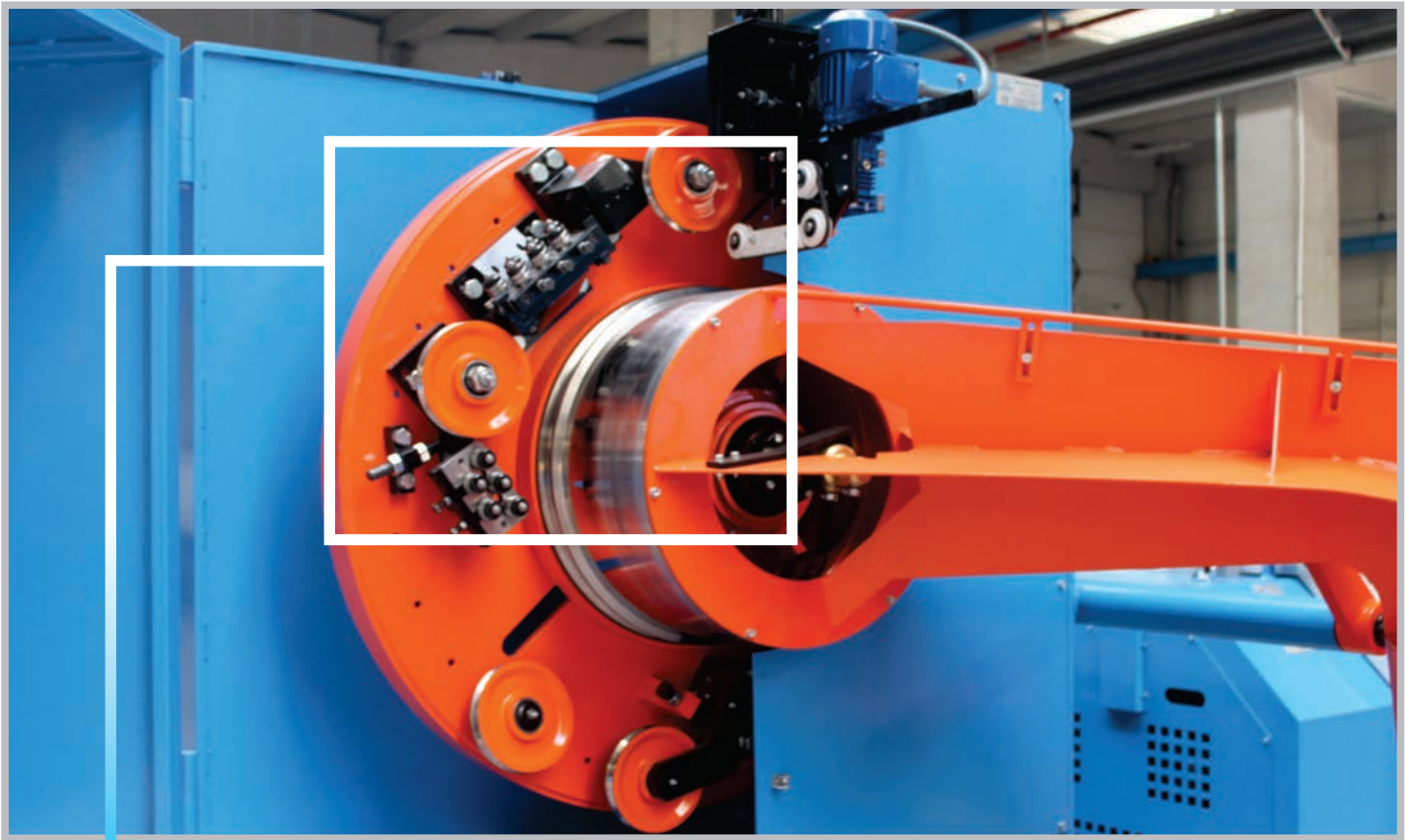

COILER

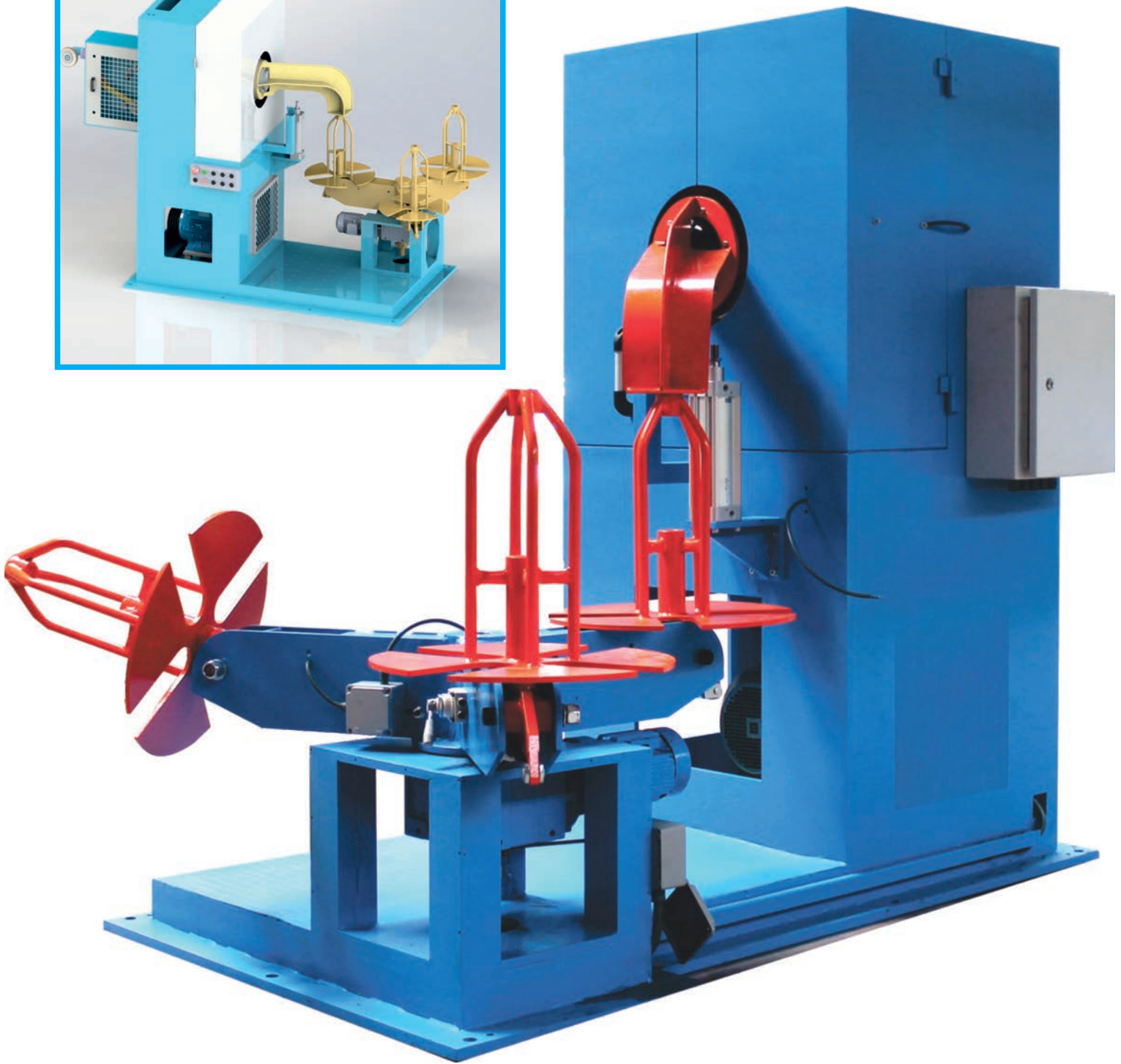
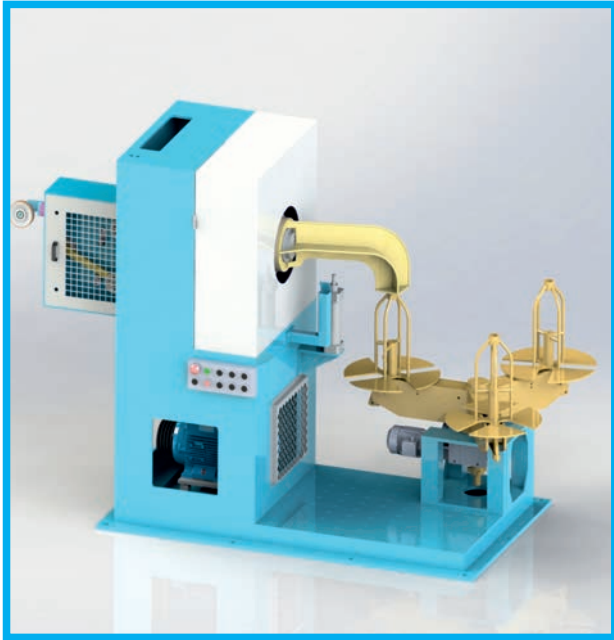

**COILER WITH
CAROUSEL TABLE MKS-CLT**



MEKOSAN

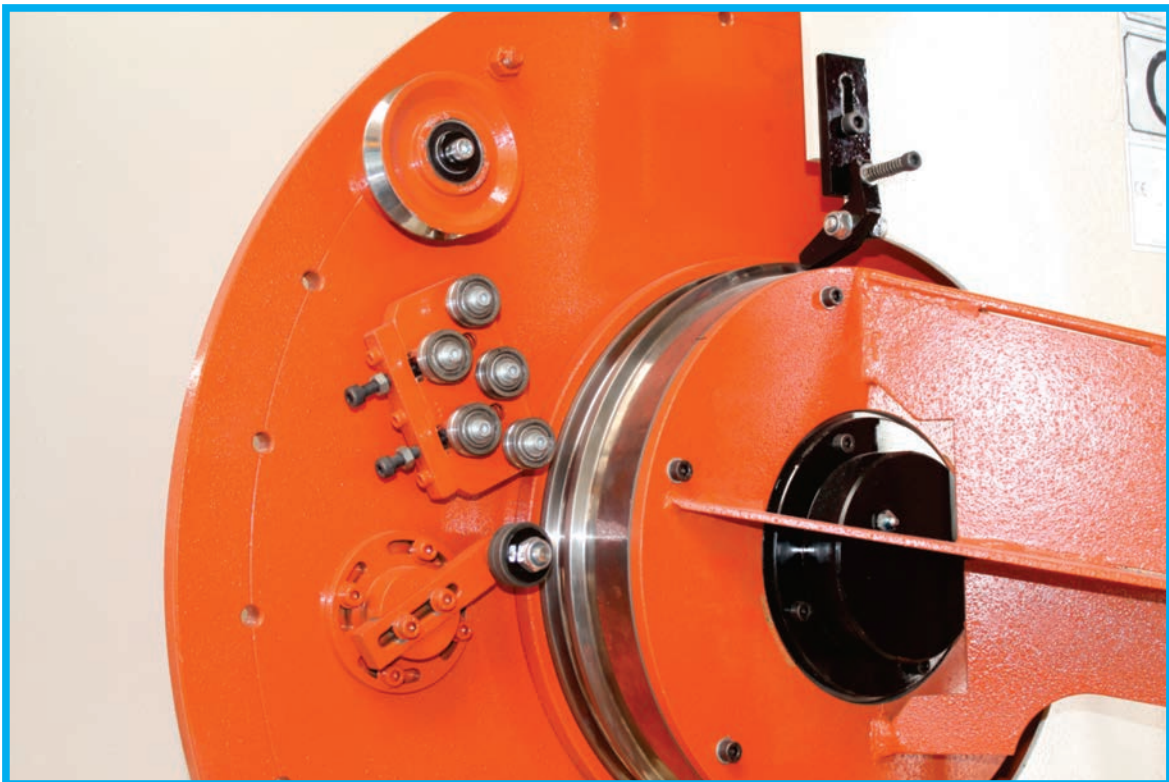
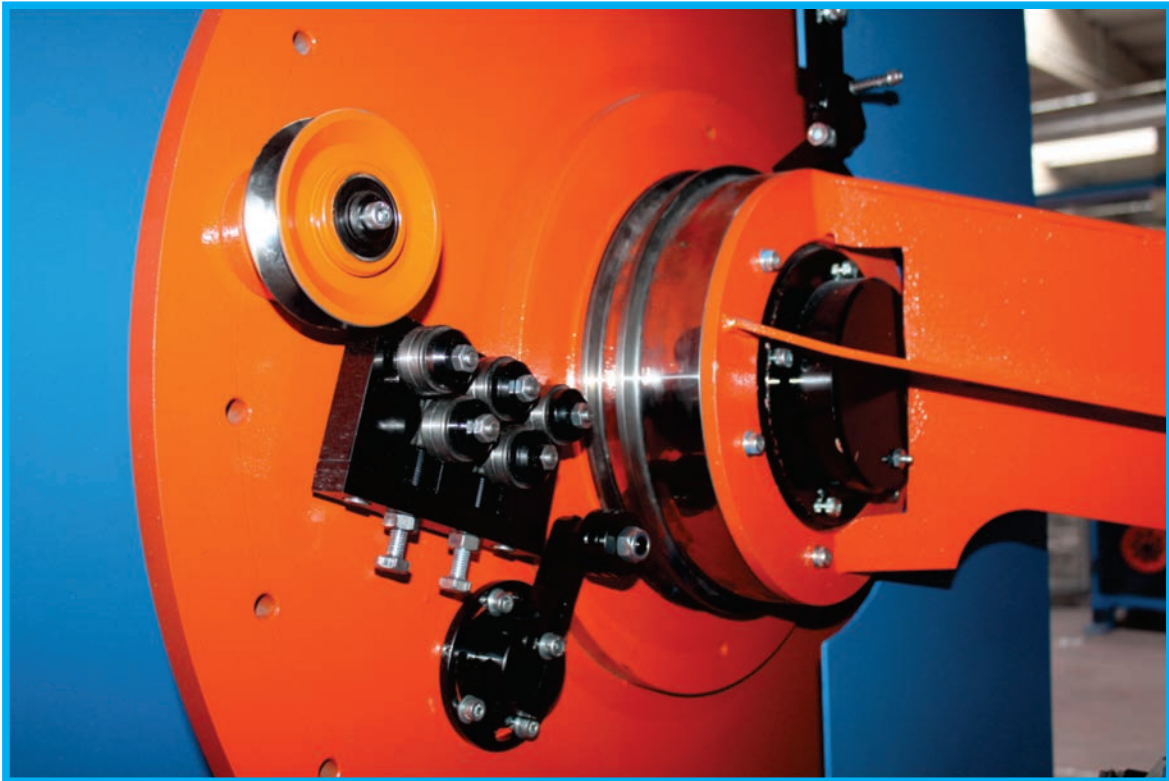

COILER



**ROZETTE SYSTEM
MKS-RZR**

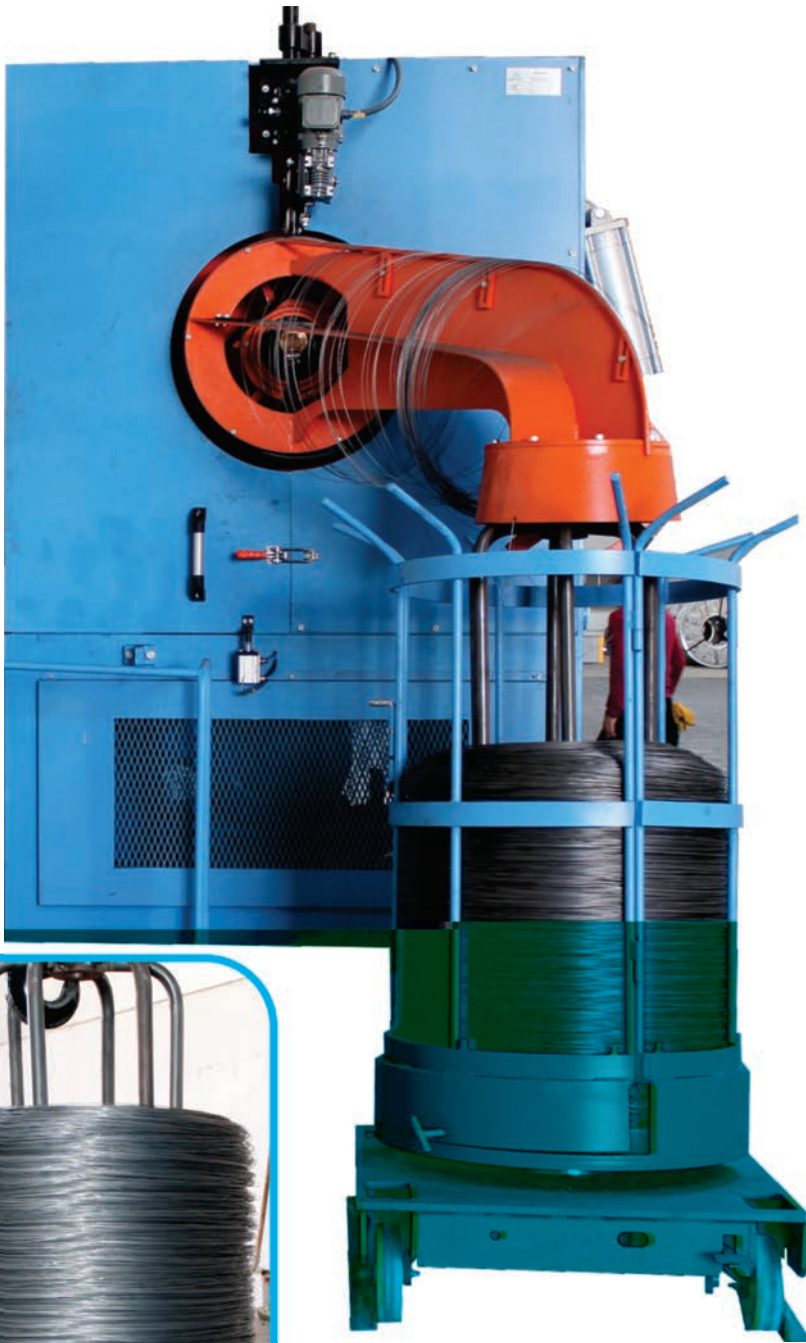

COILER

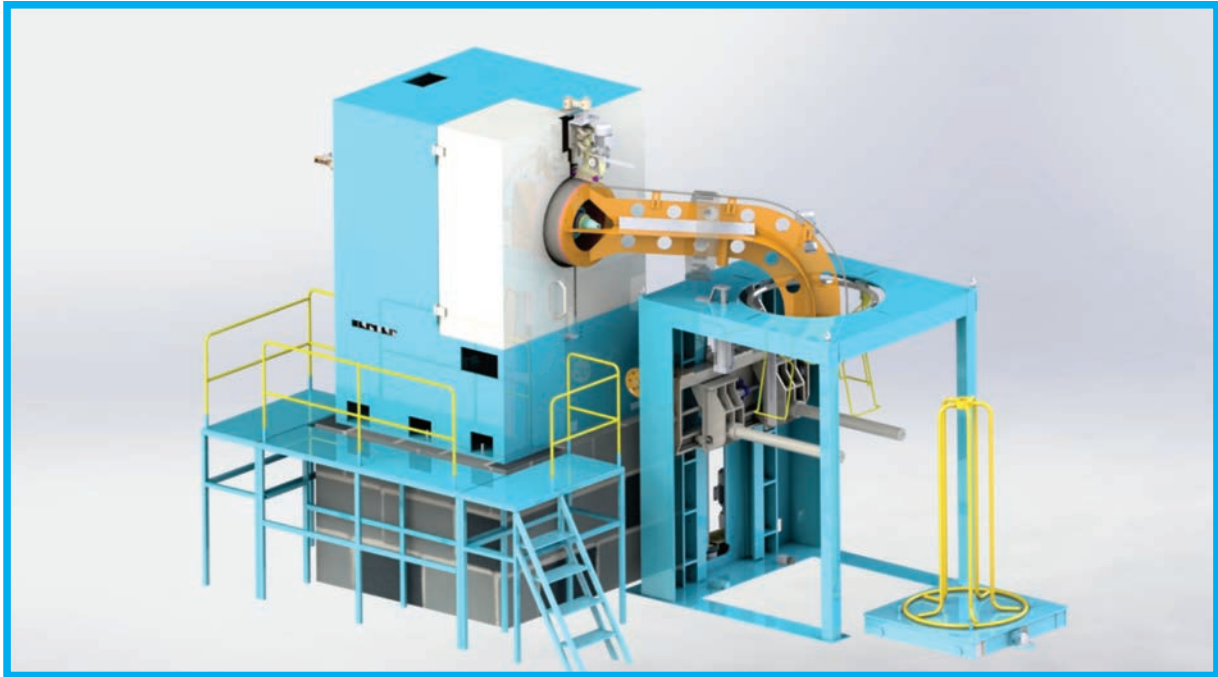
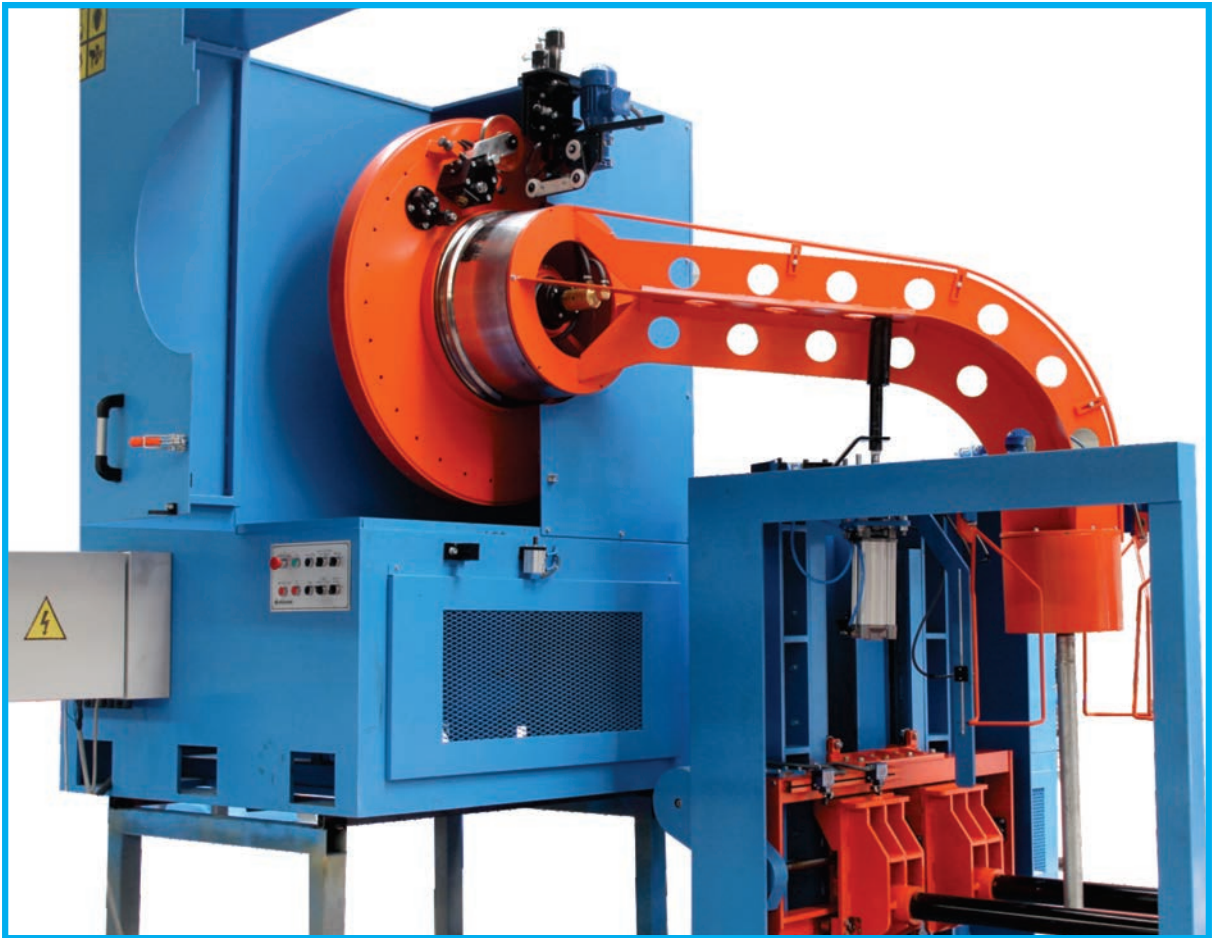

ROZETTE SYSTEM WITH LIFT MKS-RZL

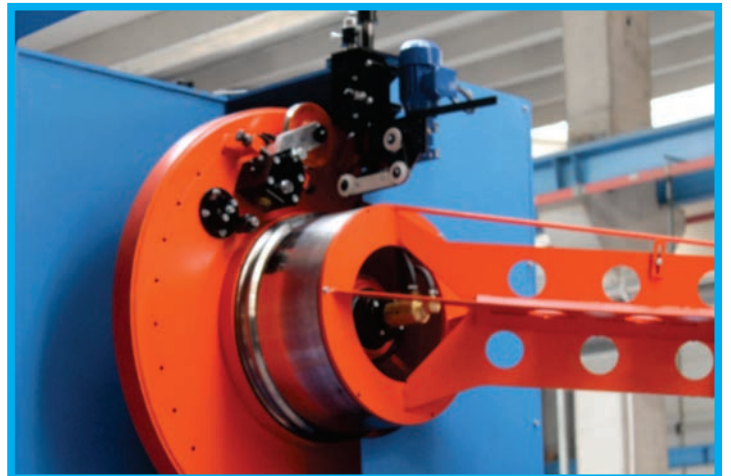
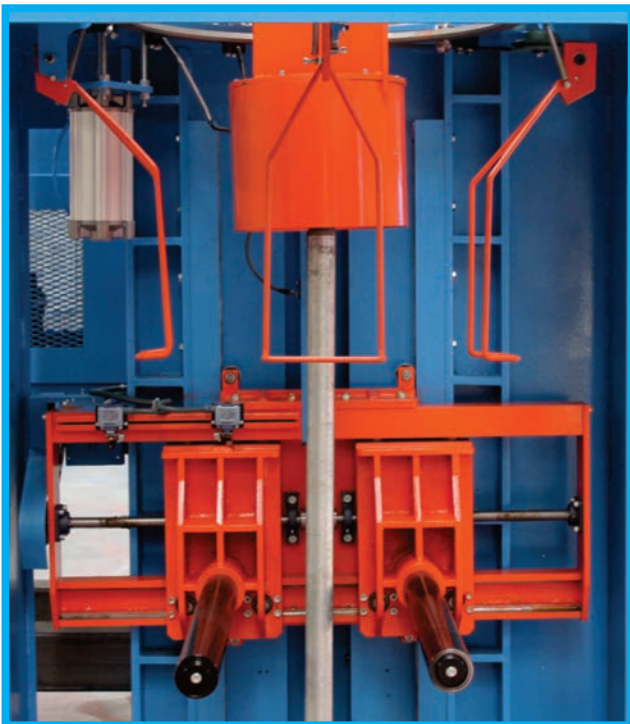

SPOOLER

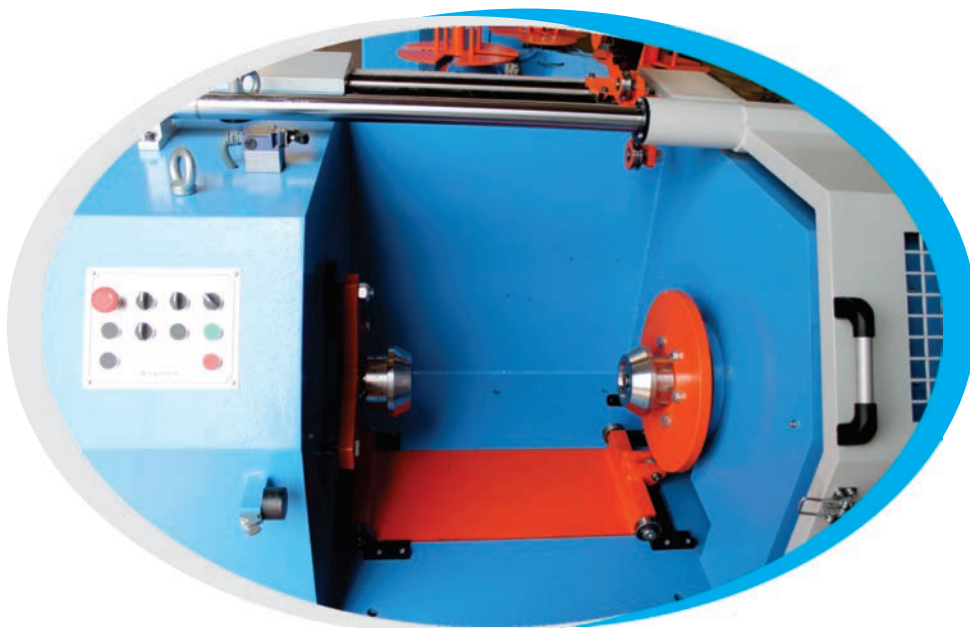
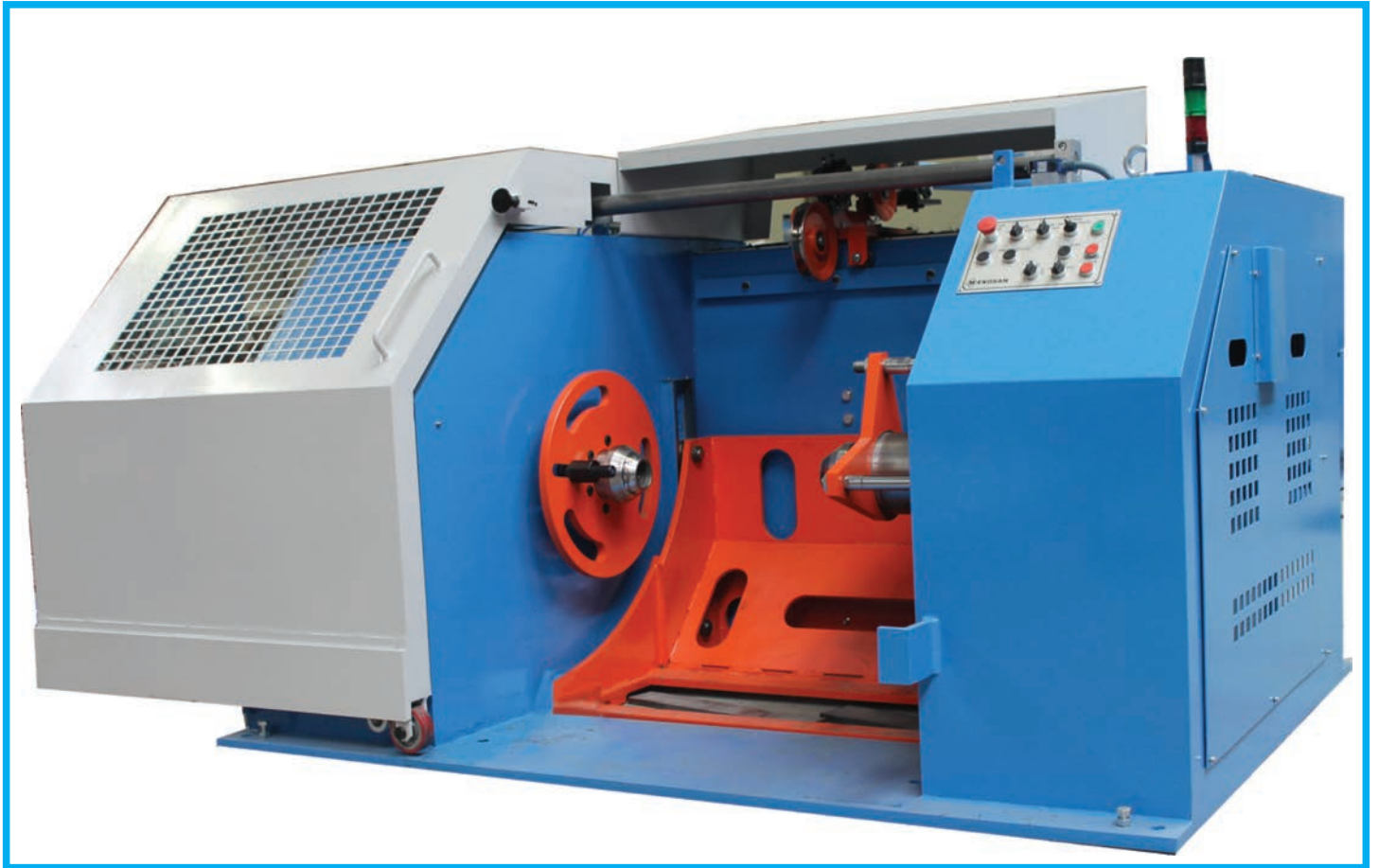

HORIZONTAL SPOOLER MKS-SPL 300 - 630

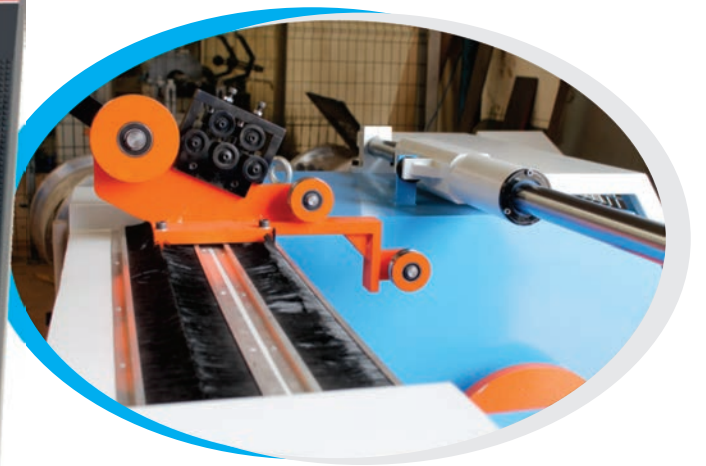
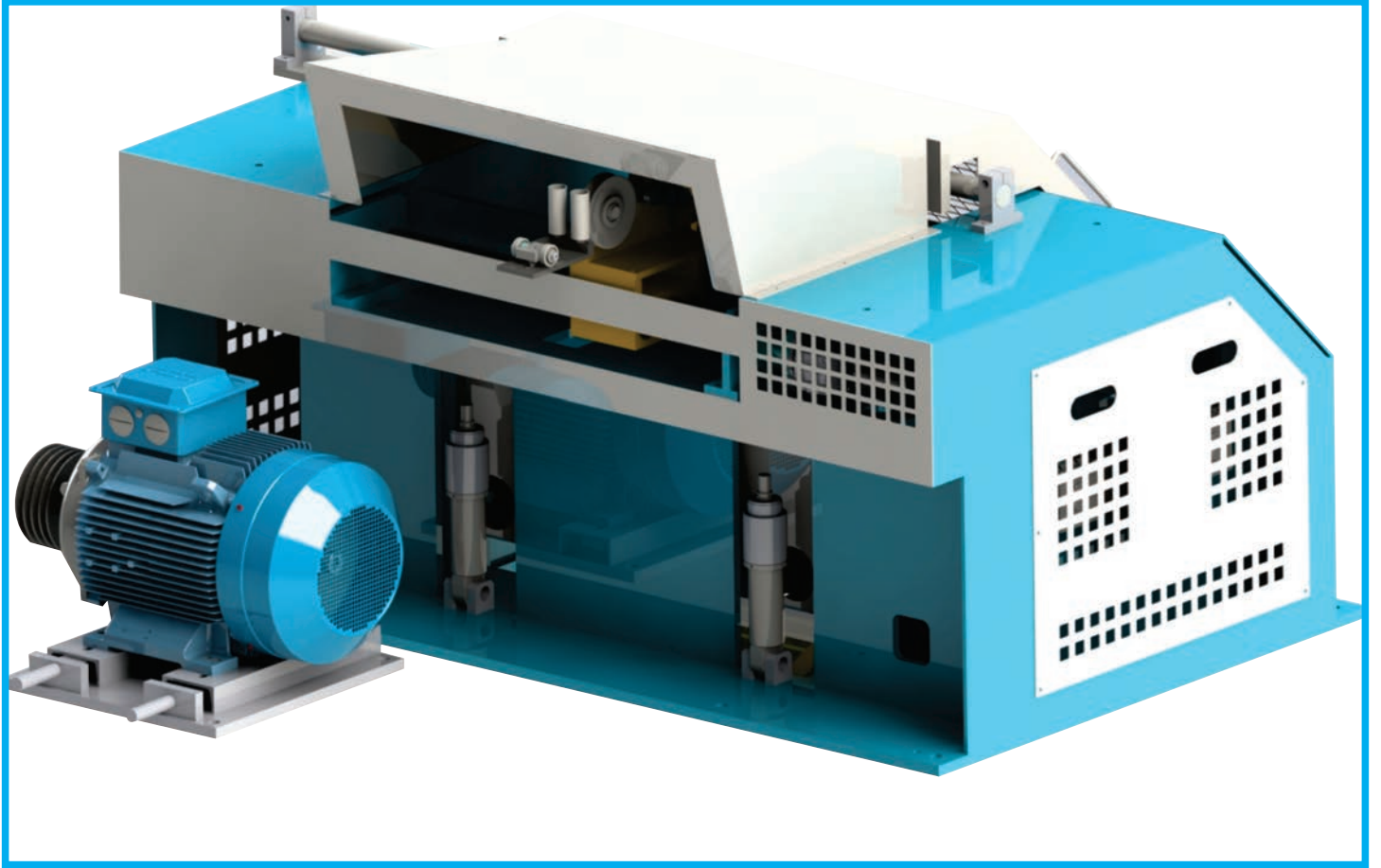

SPOOLER

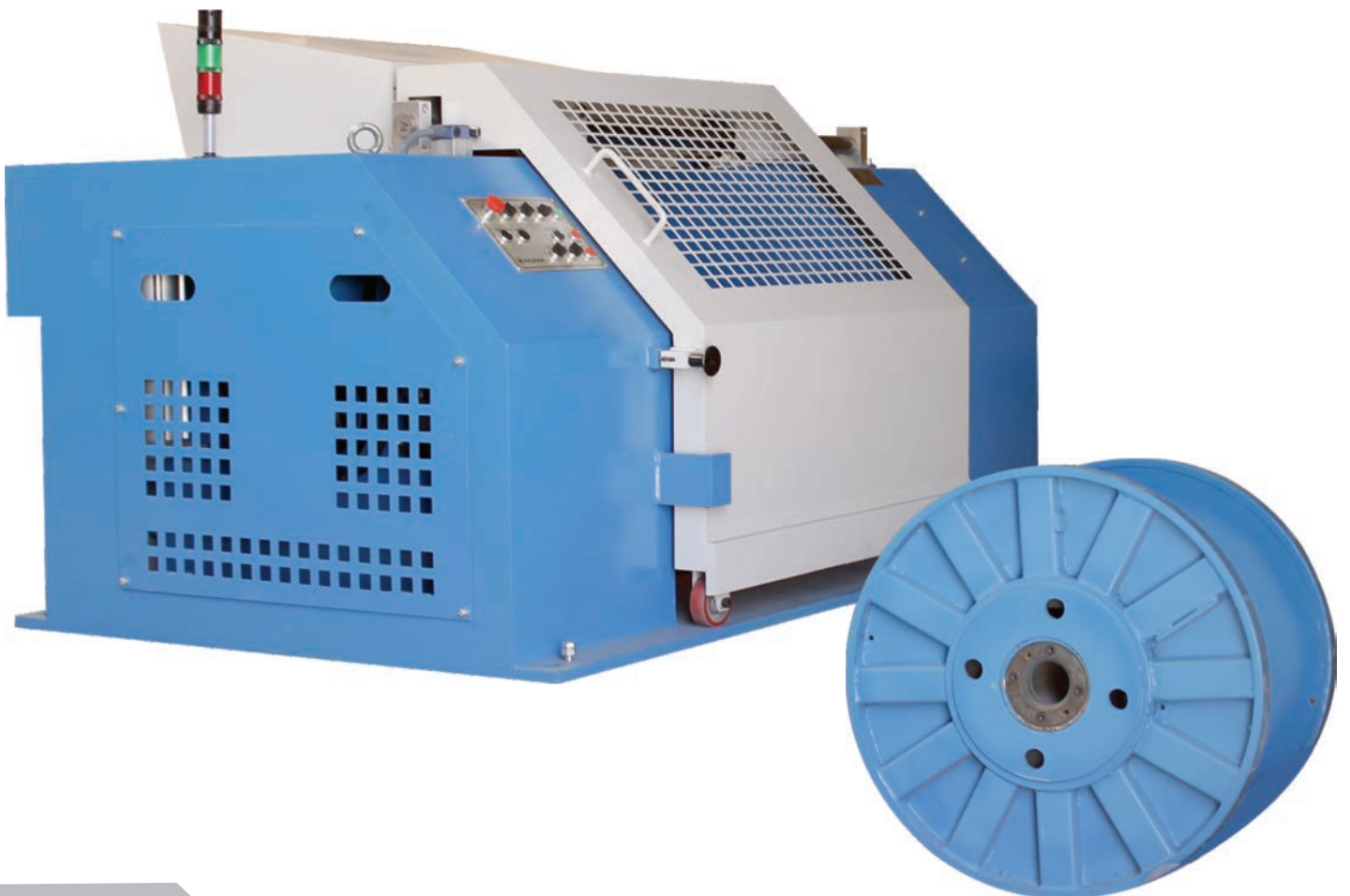

HORIZONTAL SPOOLER MKS-SPL 800 - 1250

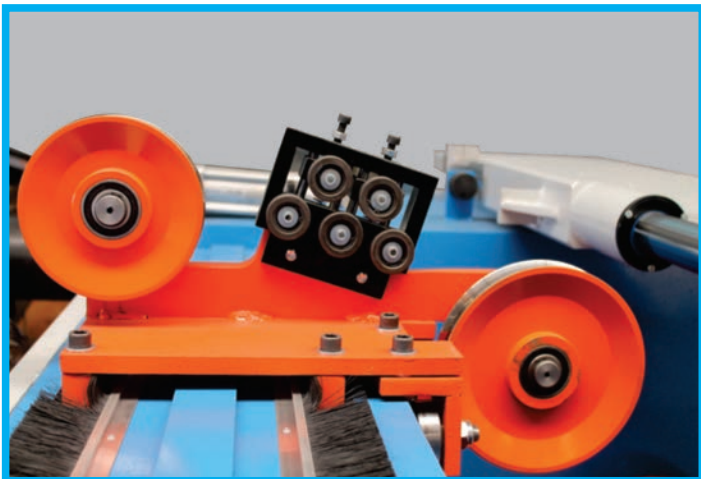
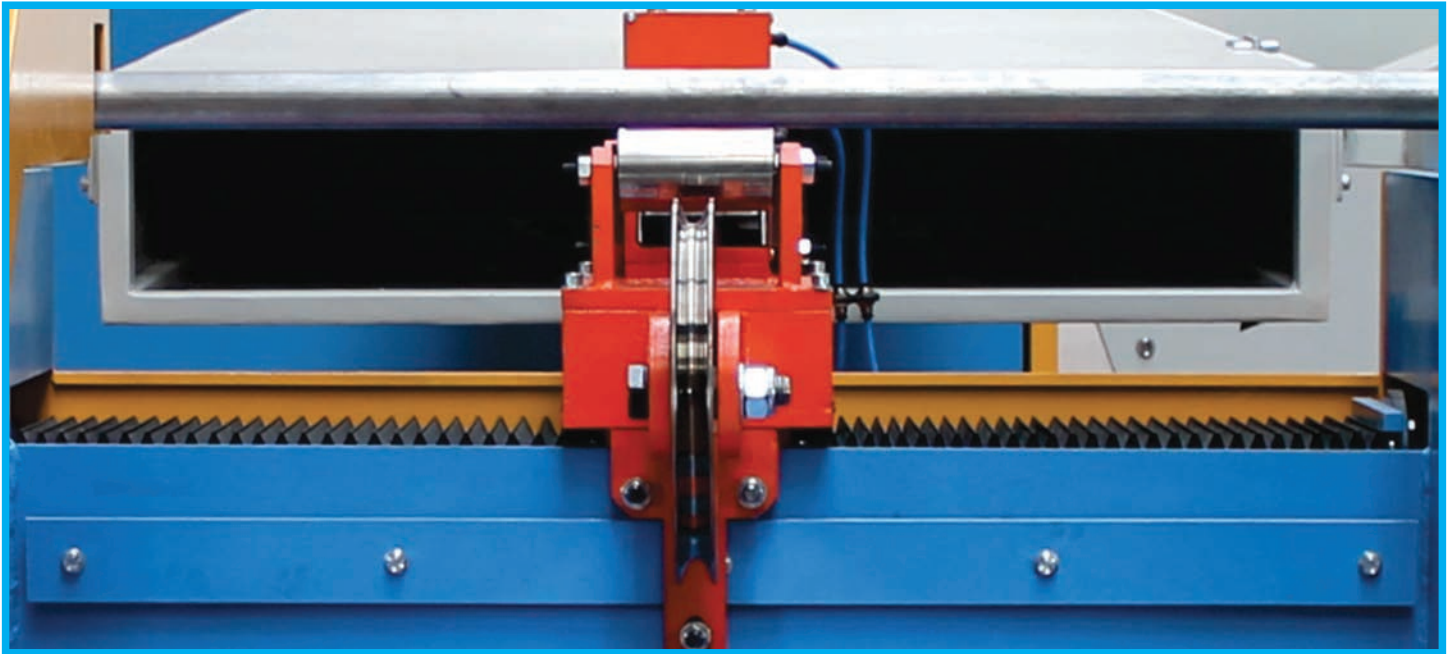
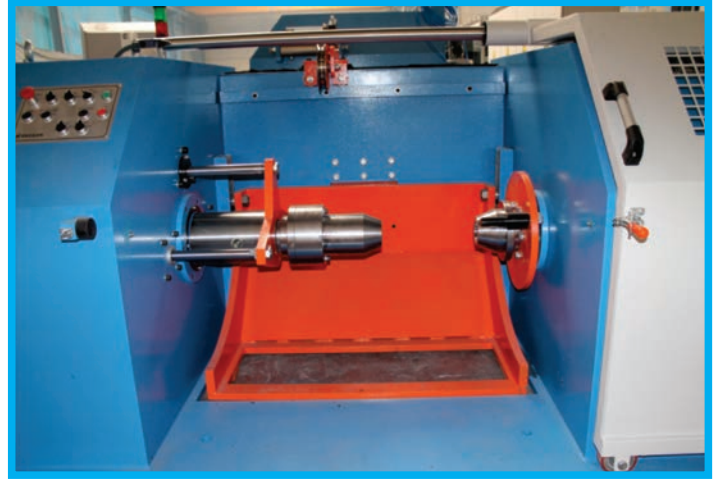
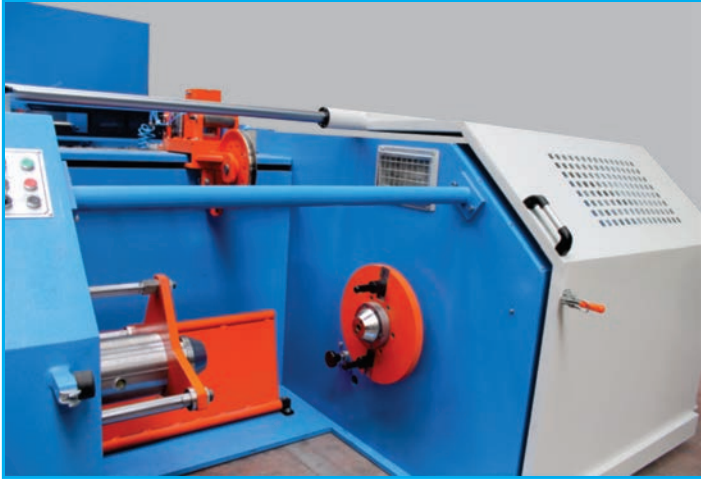

SPOOLER

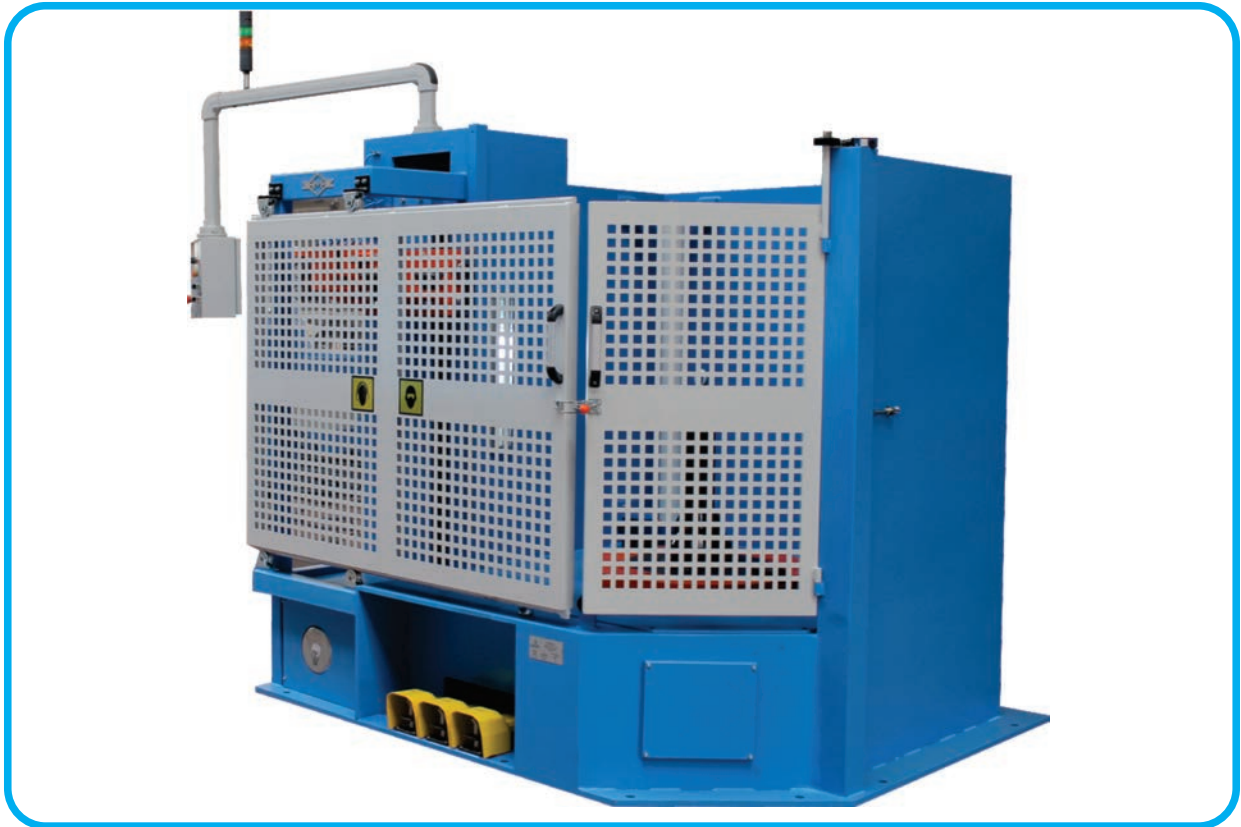

VERTICAL SPOOLER MKS-SPLV



MEKOSAN



WIRE PRE-TREATMENT MACHINES



MKS-DSC

MKS-BRS

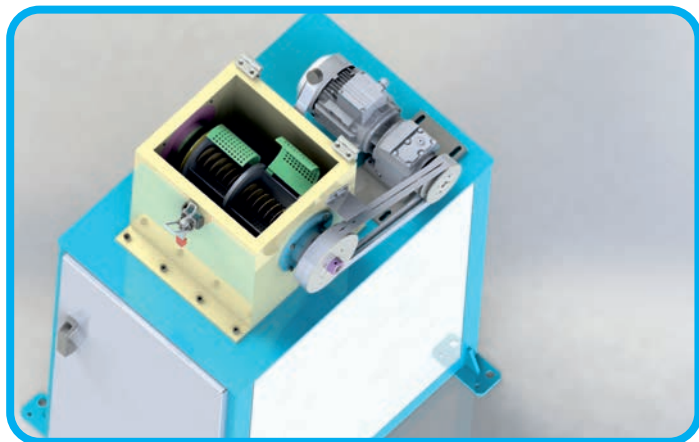

WIRE PRE-TREATMENT MACHINES

MKS-SND

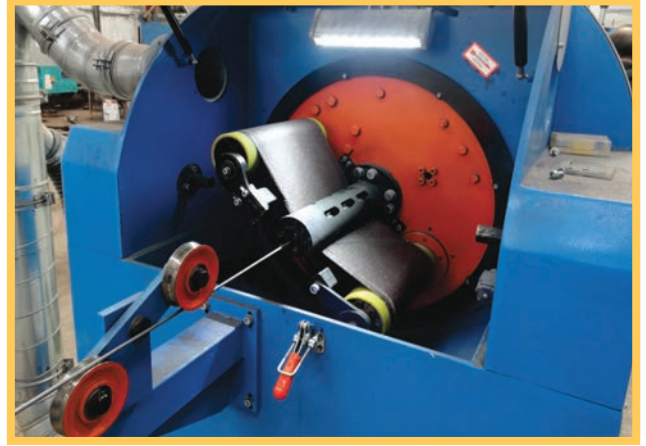



WIRE PRE-TREATMENT MACHINES



MKS-BRX

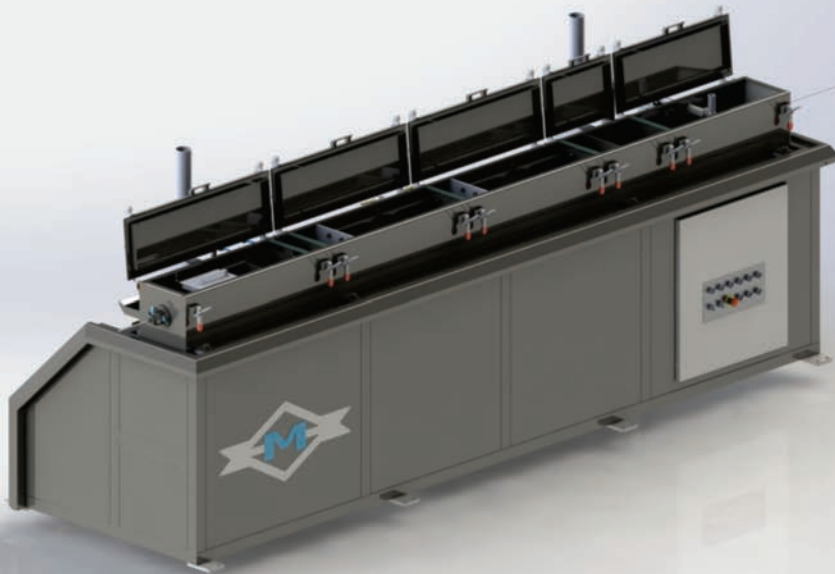

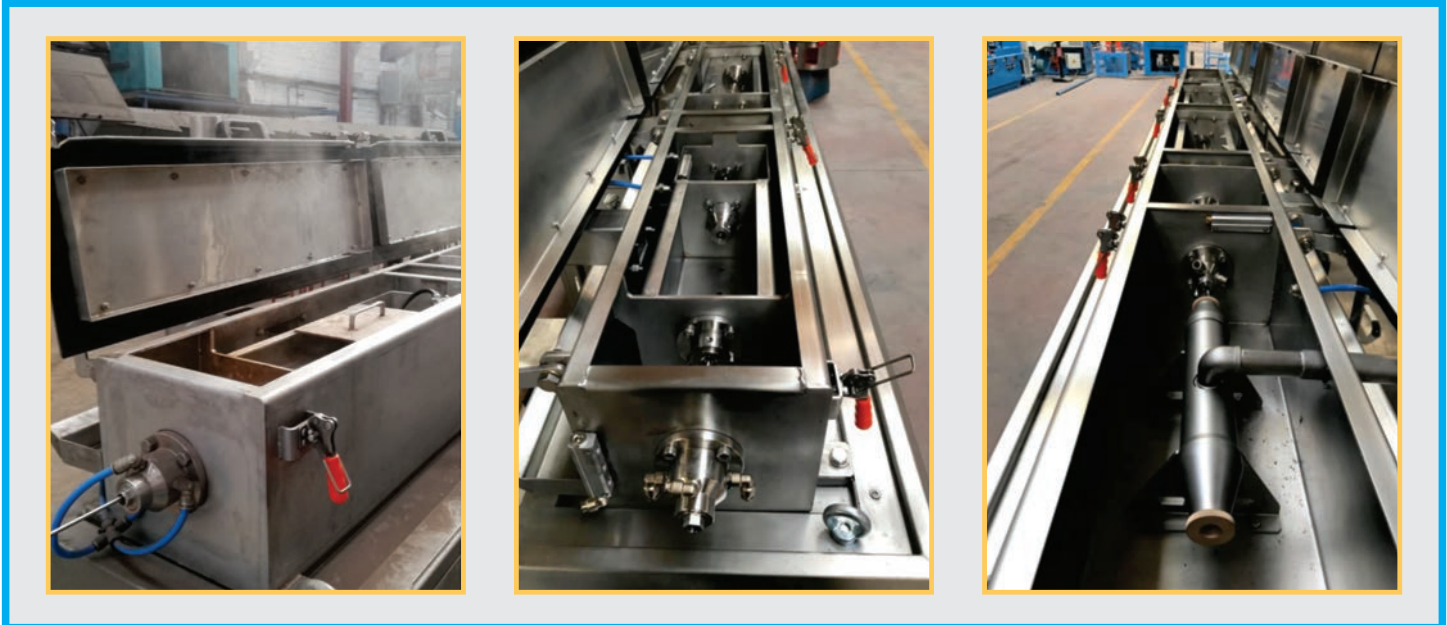

BELL TYPE ELECTRICAL ANNEALING FURNACE





BELL TYPE ELECTRICAL ANNEALING FURNACE





BELL TYPE ELECTRICAL ANNEALING FURNACE



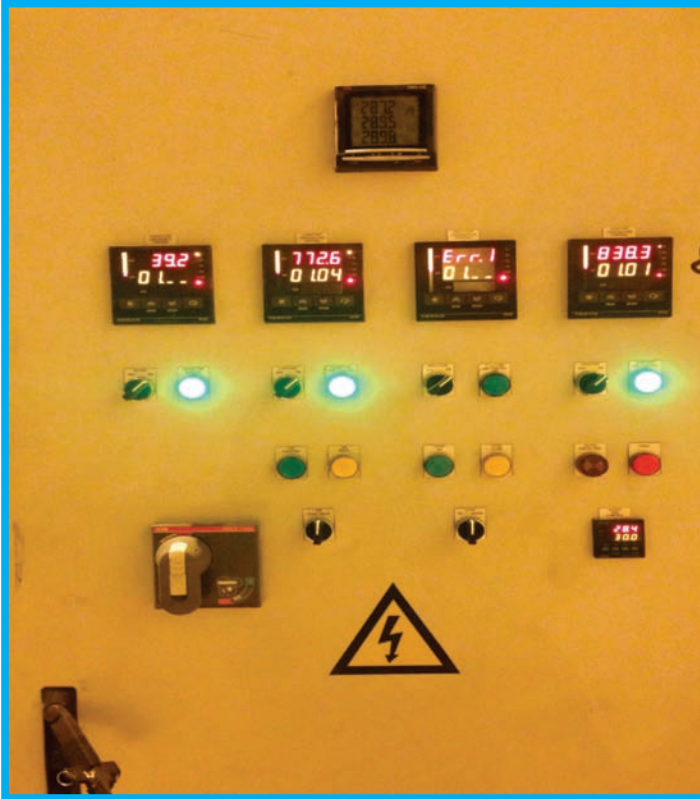

ACCESSORIES

WIRE PACKAGING MACHINE
MKS-PKG

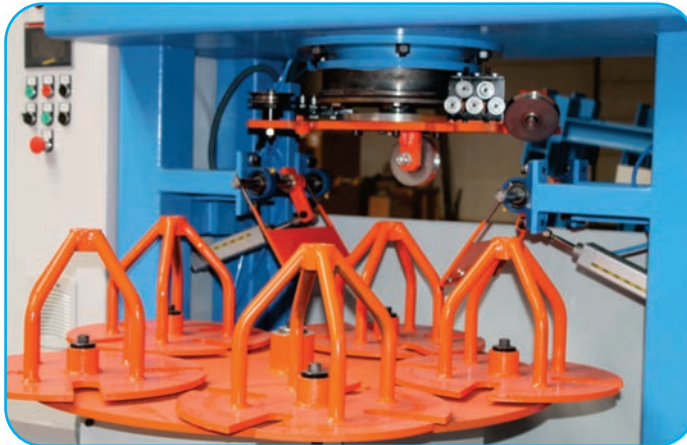
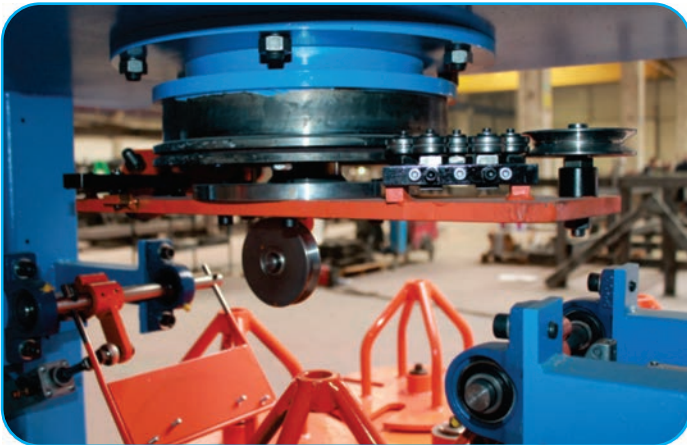



MEKOSAN

**BALING WIRE MACHINE
MKS-BL**



ACCESSORIES

COPPER COATING TANK
MKS-CCT



**DANCER
MKS-DANC**

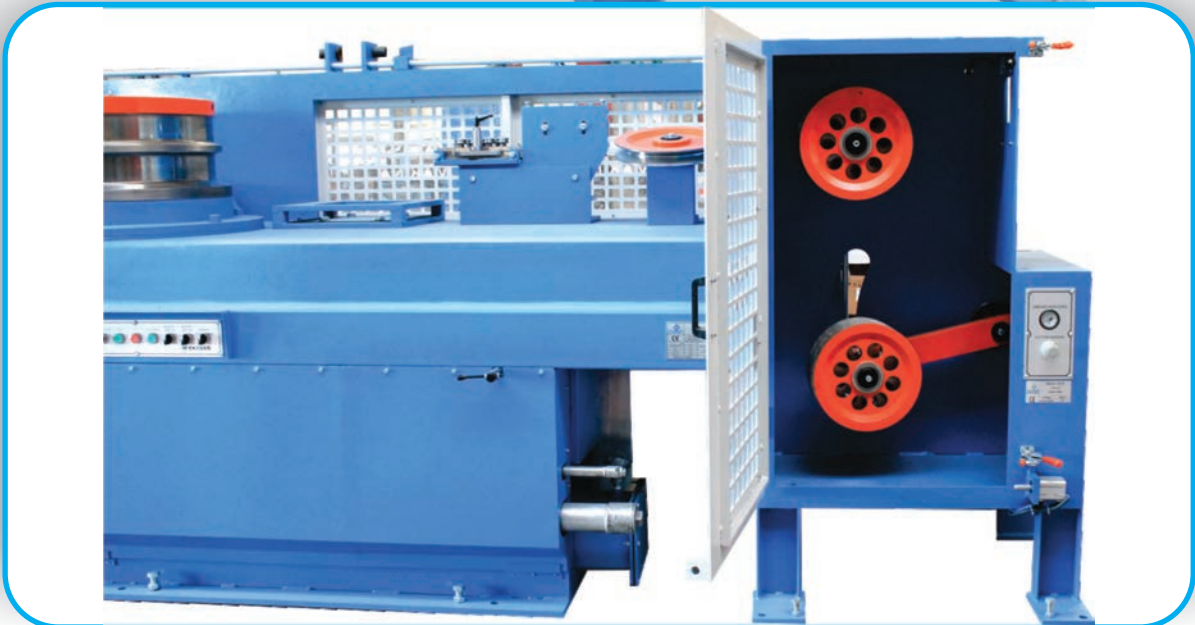

ACCESSORIES

SPOOL TILTER
MKS-SPTL





**WIRE POINTER
MKS-PNT**

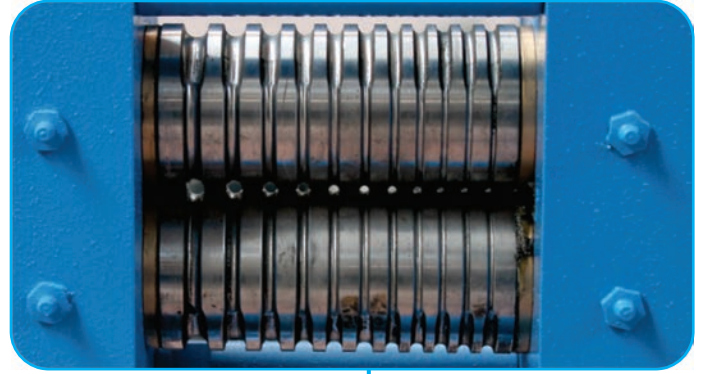
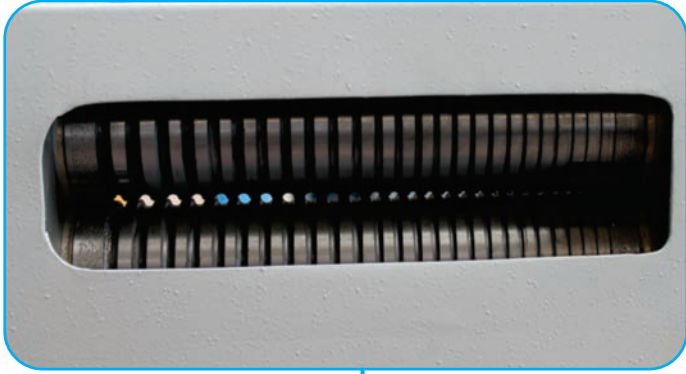

ACCESSORIES

WIRE WELDER
MKS-WLD



PULL-IN DOG



SPOOL

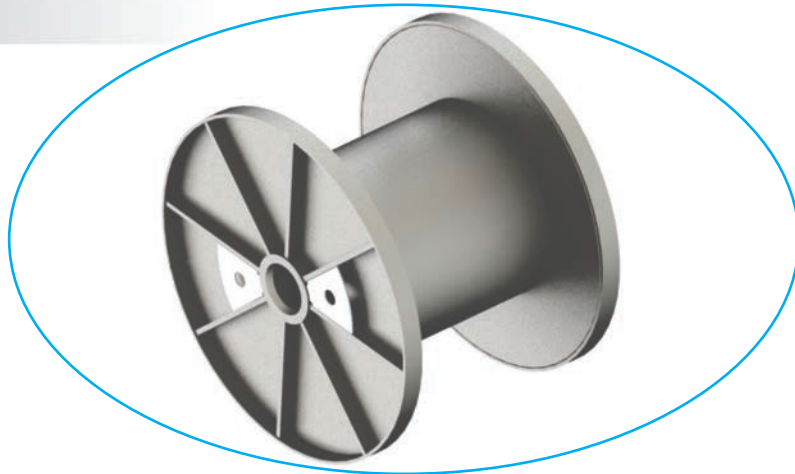

COLLAPSIBLE SPOOL

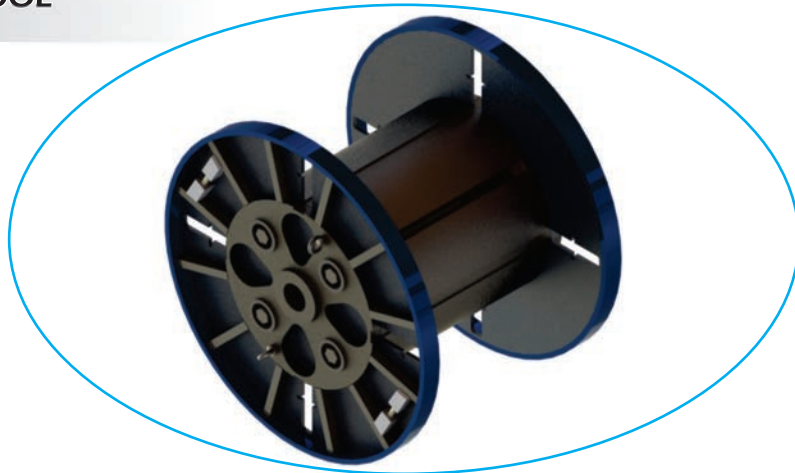

OPTIONS

ROTAITING DIE

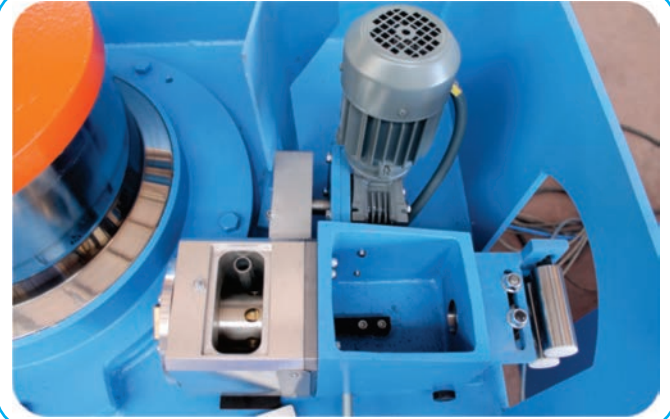

DOUBLE DECK LAST BLOCK

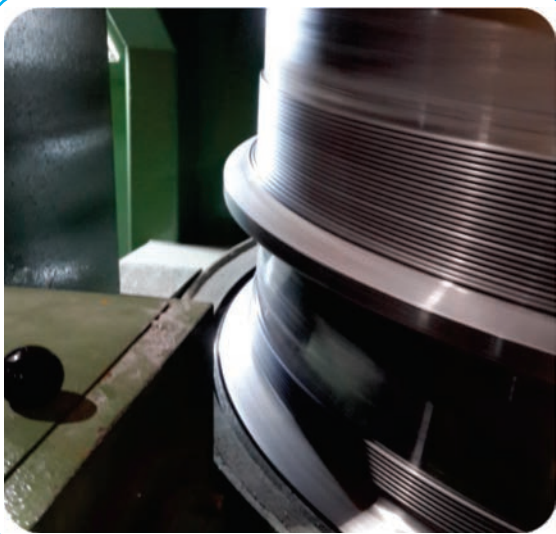

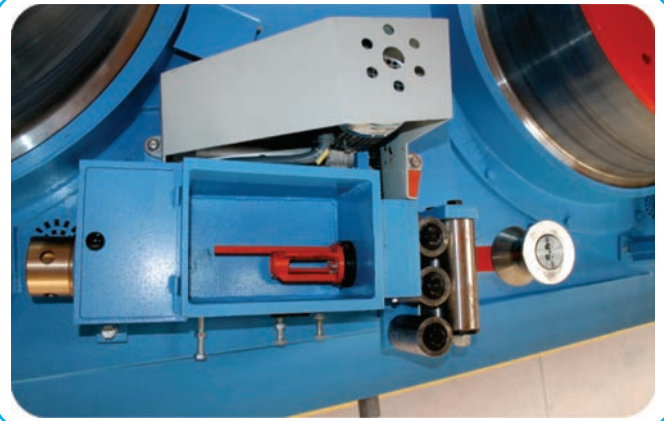
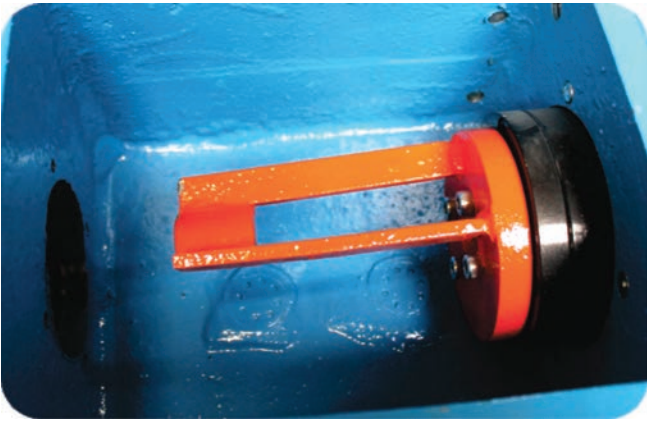
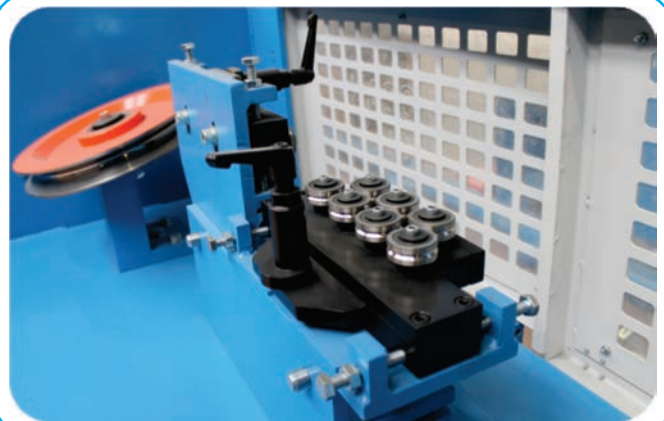
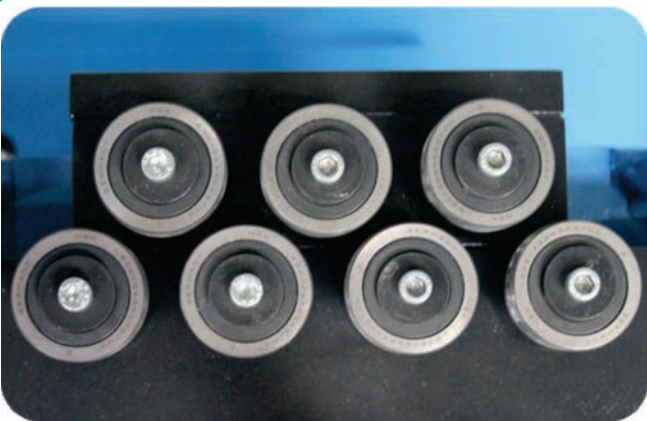
LUBRICANT MIXER**STRAIGHTENING DEVICE**

OPTIONS

VIBRATION DAMPING DEVICE

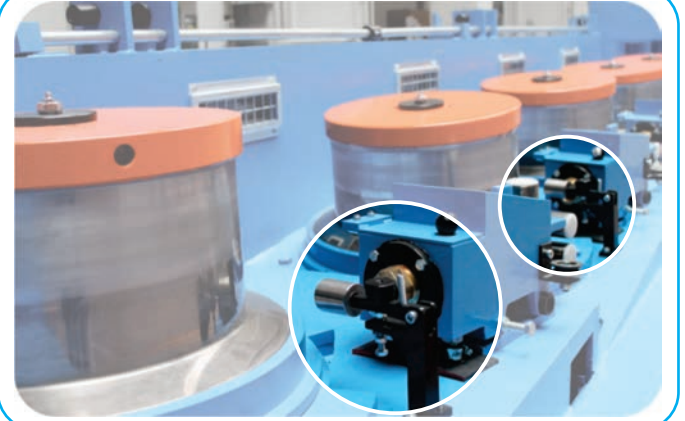

STRIPPER BLOCK

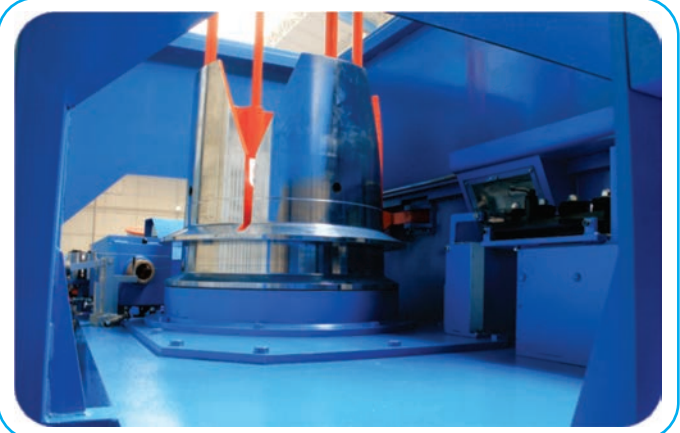
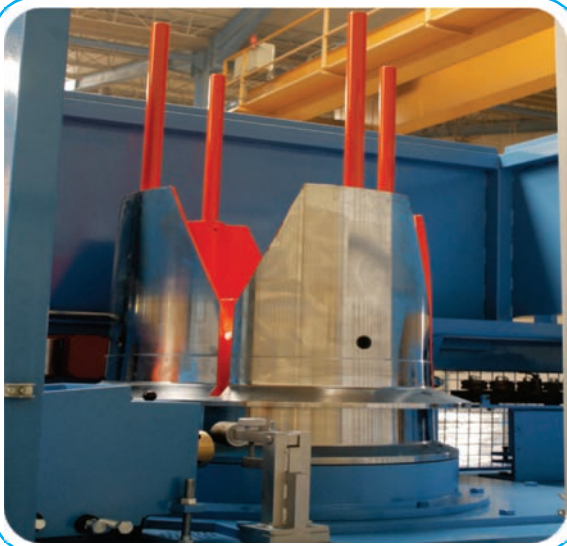

SKIN PASS UNIT

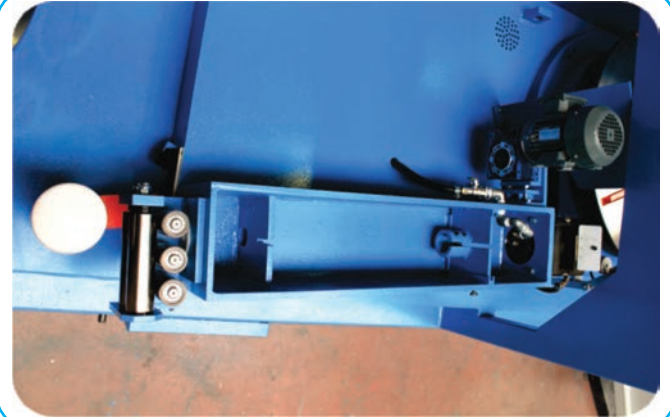

DUST EXTRACTION



OPTIONS

CASSETTE

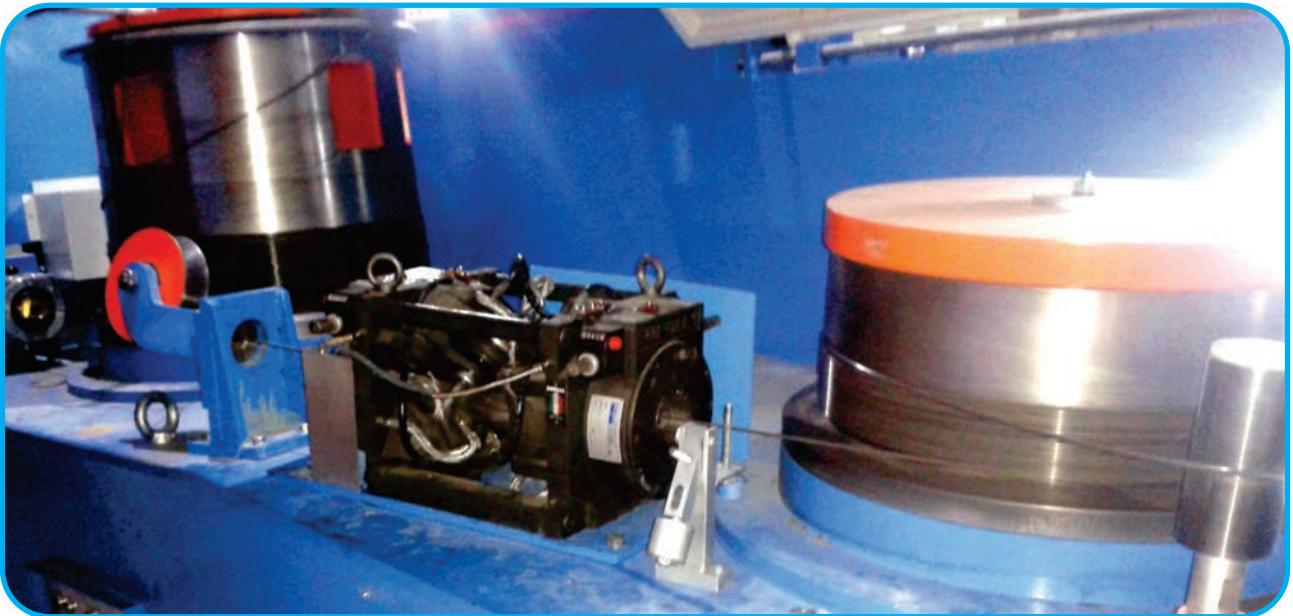



Automation Products & Services:

- Drives.
- PLCs.
- Operator Panels.
- General Performance Motors.
- High Dynamic Performance Motors.
- Explosion Proof Ac Motors.
- Electrical Installations and Control Products.
- Robots.
- SCADA Systems.
- Service and Maintenance.



Some of Our Projects:

- Power Station Automation.
- HVAC Control System Automation.
- Water Treatment Plant Automation.
- Automatic Storage System Automation.
- Ornamental Pools Automation.
- Filling Barrage Automation.
- Mushroom Production Plant Automation.
- Spinning Machine.
- Automation.
- Silo Filling Control System Automation.



Authorized
value
provider

In addition to being a design and manufacturing organization, Mekosan is a distributor of ABB drives and motors. We are also one of only three drive alliance partners for ABB drives in the Turkish market.







MEKOSAN

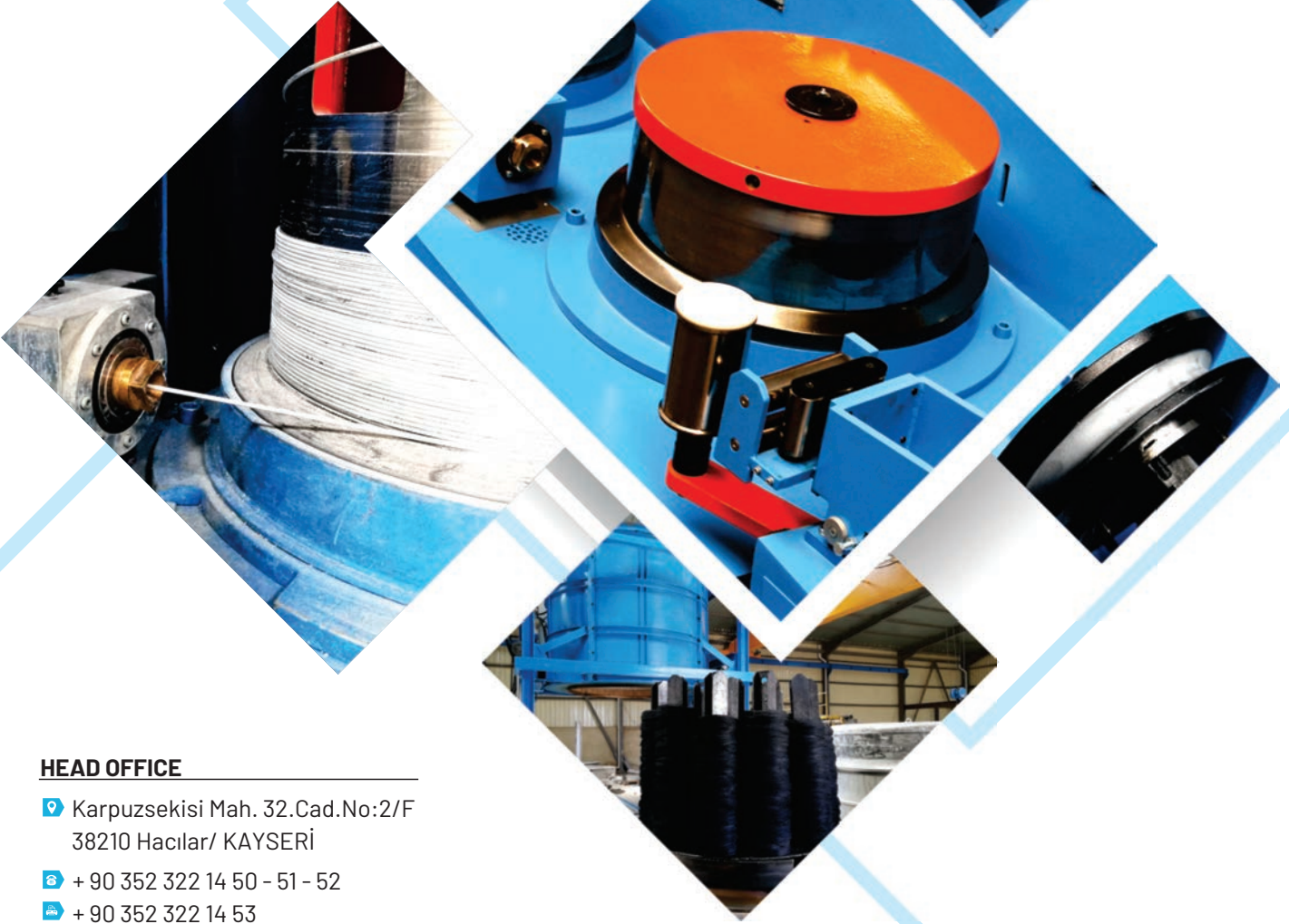

HEAD OFFICE

📍 Karpuzsekisi Mah. 32.Cad.No:2/F
38210 Hacılar/ KAYSERİ

☎ + 90 352 322 14 50 - 51 - 52

📠 + 90 352 322 14 53

FACTORY - 1

📍 Mimarşinan OSB Mah. 16.Cad.No:5
38350 Melikgazi/ KAYSERİ

FACTORY - 2

📍 Mimarşinan OSB Mah. 18.Cad.No:8
38210 Melikgazi/ KAYSERİ

🌐 www.mekosan.com.tr

✉ info@mekosan.com.tr

◆ STEEL WIRE DRAWING MACHINES

◆ HOT DEEP GALVANIZING LINES

◆ COPPER & ALUMINUM WIRE DRAWING MACHINES

